

## Dealer's Manual

ROAD	MTB	Trekking
City Touring/ Comfort Bike	URBAN SPORT	E-BIKE

# Wheel Set (Disc Brake)

### **DURA-ACE**

WH-R9270

### **ULTEGRA**

WH-R8170

### **Non-Series**

WH-RS710

# Contents

---

<b>Contents</b> .....	<b>2</b>
<b>IMPORTANT NOTICE</b> .....	<b>4</b>
<b>TO ENSURE SAFETY</b> .....	<b>5</b>
<b>List of tools to be used</b> .....	<b>9</b>
<b>Installation/removal</b> .....	<b>10</b>
Tire size .....	10
Installing/removing the cassette sprocket .....	10
Installing the disc brake rotor .....	11
Removing the disc brake rotor .....	11
<b>Maintenance</b> .....	<b>12</b>
<b>Spoke lacing</b> .....	<b>12</b>
• WH-R9270 .....	12
• WH-R8170 .....	13
• WH-RS710 .....	14
<b>Replacing the spokes</b> .....	<b>15</b>
• WH-R9270 .....	16
• WH-R8170 .....	22
• WH-RS710 .....	26
<b>Replacing tubeless tape</b> .....	<b>27</b>
<b>Front hub</b> .....	<b>31</b>
• Disassembly .....	31
• Assembly .....	35
<b>Freehub</b> .....	<b>38</b>
• Pre-work cautions (WH-R9270) .....	38
• Disassembly (WH-R9270) .....	39
• Disassembly (WH-R8170 / WH-RS710) .....	45
• Assembly (WH-R9270) .....	49
• Assembly (WH-R8170 / WH-RS710) .....	56
<b>Replacing the freewheel body unit</b> .....	<b>57</b>

- WH-R9270 ..... 57
- WH-R8170 / WH-RS710..... 58
- Installing and removing the tubeless tires..... 59**
  - Installation ..... 60
  - Removal ..... 62
  - Installing an inner tube..... 63
- Cautions regarding the use of tubular tires and rims ..... 64**



# IMPORTANT NOTICE

- **This dealer's manual is intended primarily for use by professional bicycle mechanics.** Users who are not professionally trained for bicycle assembly should not attempt to install the components themselves using the dealer's manuals. If any part of the information on the manual is unclear to you, do not proceed with the installation. Instead, contact your place of purchase or a distributor for assistance.
- Make sure to read all manuals included with each product.
- Do not disassemble or modify the product other than as stated in the information contained in this dealer's manual.
- All manuals and technical documents are accessible online at <https://si.shimano.com>.
- For consumers who do not have easy access to the internet, please contact a SHIMANO distributor or any of the SHIMANO offices to obtain a hardcopy of the User's Manual.
- Please observe the appropriate rules and regulations of the country, state or region in which you conduct your business as a dealer.

**For safety, be sure to read this dealer's manual thoroughly before use, and follow it for correct use.**

The following instructions must be observed at all times in order to prevent personal injury and physical damage to equipment and surroundings.

The instructions are classified according to the degree of danger or damage which may occur if the product is used incorrectly.

 <b>DANGER</b>	Failure to follow the instructions will result in death or serious injury.
 <b>WARNING</b>	Failure to follow the instructions could result in death or serious injury.
 <b>CAUTION</b>	Failure to follow the instructions could cause personal injury or physical damage to equipment and surroundings.

# TO ENSURE SAFETY

## WARNING

- **Be sure to follow the instructions provided in the manuals when installing the product.** Only use SHIMANO genuine parts. If a component or replacement part is incorrectly assembled or adjusted, it can lead to component failure and cause the rider to lose control and crash.
-  Wear approved eye protection while performing maintenance tasks such as replacing components.

### Be sure to also inform users of the following:

- **Check that the wheels are fastened securely before riding the bicycle.** Using the axle release lever incorrectly may cause the wheel to fall off, etc. and lead to serious injury due to a fall.
- Before riding the bicycle, check the wheels to make sure that there are no bent or loose spokes, dents, scratches or cracks on the rim surface. Do not use the wheel if any of these problems are found. The wheel may break, and you may fall. Check also that there is no carbon separation or cracking.
- Do not use the Road Wheel Set on unpaved surfaces. The Road Wheel Set is designed for paved surfaces. If the wheels are used on unpaved surfaces, they may become bent or damaged, and accidents may result.
- Do not use with rim brakes. These wheels are designed exclusively for use with disc brakes. Using these wheels with rim brakes could damage the rims and result in an accident that can lead to a serious injury or even death.
- Make sure that, even if the axle release lever is tightened as much as possible by hand, the axle release lever does not interfere with the disc brake rotor. The axle release lever may interfere with the disc brake rotor if it is on the disc brake rotor side, which is dangerous. If the axle release lever interferes with the disc brake rotor, immediately stop use and contact the place of purchase or a distributor.

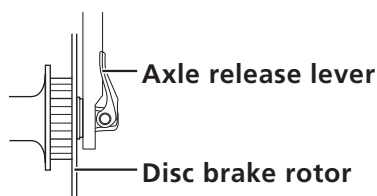

- Do not touch the calipers or disc brake rotor while riding or immediately after dismounting from the bicycle. The calipers and disc brake rotor will become hot when the brakes are operated, so you may get burned if you touch them. Check that the brake system has cooled down sufficiently before attempting brake system maintenance.
- Do not allow any oil or grease to get onto the disc brake rotor and brake pads. Riding the bicycle with oil or grease on the disc brake rotor and brake pads may prevent the brakes from operating and result in serious injury due to a fall or collision.
- Read the disc brake manual carefully, and keep it in a safe place for later reference.
- Use the appropriate air pressure indicated on the tire and rim. If the maximum pressure indicated on the tire and rim differ, be sure not to exceed the lower value.
- For details on the E-THRU axle, refer to the E-THRU axle user's manual.

## **F12 (Front 12 mm Axle), R12 (Rear 12 mm Axle) Wheel (Thru Axle)**

- This wheel can only be used in combination with the special front fork/frame and the through axle. If it is used in combination with any other front fork/frame or through axle, it may cause the wheel to become detached from the bicycle during riding and result in serious bodily injury.

## **TL: Tubeless wheel**

- The tires should be installed and removed by hand. If this is difficult, a resin tire lever for tubeless wheels may be used. In such cases, be sure to check that the rim surface has not been dented, scratched, or cracked as there is a risk of causing damage to the air seal between the tire and the rim, which would result in air leakage. For carbon rims, check that there is no carbon peeling or cracking, etc. Finally, make sure that there is no air leakage.
- Use the appropriate air pressure indicated on the tire and rim. If the maximum pressures indicated on the tires and rims differ, be sure not to exceed the maximum pressure with the lower value. A higher pressure than indicated can cause a sudden puncture and/or sudden release of the tire, which can result in serious injury.  
WH-R9270 / WH-R8170 / WH-RS710: Maximum pressure = 7.5 bar / 109 psi / 750 kPa

## **TU: Tubular wheel**

- Before riding the bicycle, check that the tires are securely glued to the rims. If the tires come off while riding, you may fall and get severely injured.

**⚠ CAUTION****Be sure to also inform users of the following:**

- If you will be using tire sealant, consult the place of purchase or a distributor. Tire sealant may damage the tire and rim.

**TL: Tubeless wheel**

- When using an inner tube, do not add additional rim tape on top of the tubeless tape. Doing so may make it difficult to install or remove the tire, and it may cause damage to the inner tube resulting in a sudden puncture, which can cause the bicycle to fall over.
- Be sure to use tubeless tape when using these wheels.
- Do not use tape other than genuine SHIMANO tubeless tape. Otherwise, a sudden puncture may occur, and you may fall off the bicycle.
- If you use a tire such as a Tubeless Ready tire that needs to be used with a sealant, use the sealant recommended by the tire manufacturer.
- Do not overtighten the valve lock ring. If you tighten the valve lock ring too much, the valve seal may become deformed, and air leaks may occur.

**For installation to the bicycle and maintenance**

- Refer to the tire size table in the "Installation/removal" section when selecting tires.
- Read the tire manual carefully, and keep it in a safe place for later reference.

**NOTICE****Be sure to also inform users of the following:**

- Use only the lubricants specified by SHIMANO.
- It is recommended that you ask a place of purchase to adjust the spoke tensions if there is any deviation in the spokes and after the first 1,000 km of riding.
- Optional reflector and spoke protector sets are available. Check the model number on the website specifications and please ask your bicycle dealer for details.
- Do not use detergent or other chemicals when wiping the wheel, otherwise, the sticker on the rim may come off.
- Products are not guaranteed against natural wear and deterioration from normal use and aging.

- For maximum performance we highly recommend SHIMANO lubricants and maintenance products.









## For installation to the bicycle and maintenance

- Use only genuine SHIMANO spokes and nipples. Otherwise, the area where the spokes fit into the hub body may become damaged.
- Be careful not to overtighten the nipples when adjusting the spoke tensions. If overtightened, damage to the rim may result.
- If the wheel becomes stiff and difficult to turn, perform an inspection.
- Special nipple wrenches are available as optional accessories.
- Check the specifications table (<https://si.shimano.com>) for compatible reflectors and spoke protectors.
- For information on how to install and remove the tires, refer to the manual accompanying the tire.

The actual product may differ from the illustration because this manual is intended mainly to explain the procedures for using the product.

# List of tools to be used

The following tools are necessary for installation/removal, adjustment, and maintenance purposes.

Tool	
	17 mm hub spanner x 2
	22 mm hub spanner
	TL-FH15
	TL-FH17
	TL-LR15
	TL-WHR92
	Slotted screwdriver
	24 mm hub spanner / adjustable wrench

# Installation/removal

## Tire size

The recommended tire sizes for installation to each wheel are as follows.

	Wheel size	Model name	Tire size
DURA-ACE	622 x 21C	WH-R9270-C36-TL	25-622 - 32-622
		WH-R9270-C50-TL	
		WH-R9270-C60-HR-TL	
	700C	WH-R9270-C36-TU	25-28" - 32-28"
		WH-R9270-C50-TU	
		WH-R9270-C60-HR-TU	
ULTEGRA	622 x 21C	WH-R8170-C36-TL	25-622 - 32-622
		WH-R8170-C50-TL	
		WH-R8170-C60-TL	
Non-Series	622 x 21C	WH-RS710-C32-TL	25-622 - 32-622
		WH-RS710-C46-TL	

## Installing/removing the cassette sprocket

Refer to the dealer's manual for the cassette sprocket to install/remove the cassette sprocket.

### NOTICE

- When using a lock ring tightening tool from another company, ensure that the tool does not interfere with the dust cover of the right cap. Damage to the dust cover or deviation from the specified position may affect the rotation performance and waterproofing performance.

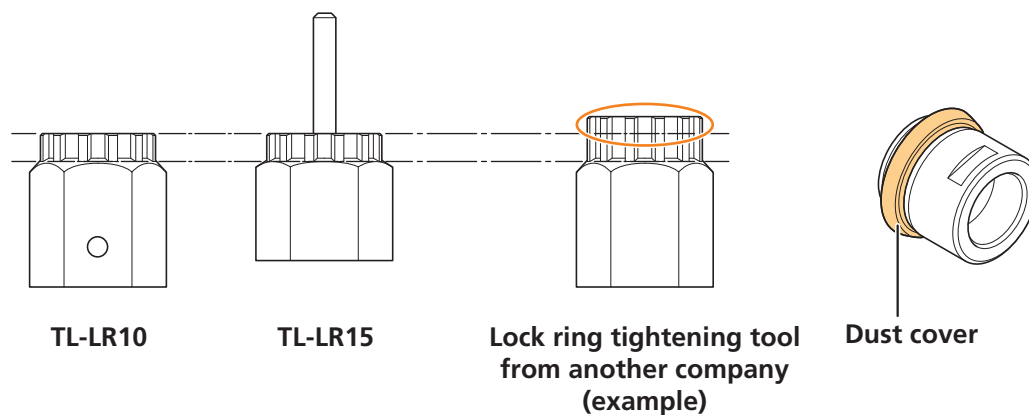

# Installing the disc brake rotor

1. Set the disc brake rotor on the hub, then secure it with the disc brake rotor lock ring.

Secure with TL-LR15 and 24 mm hub spanner / adjustable wrench.

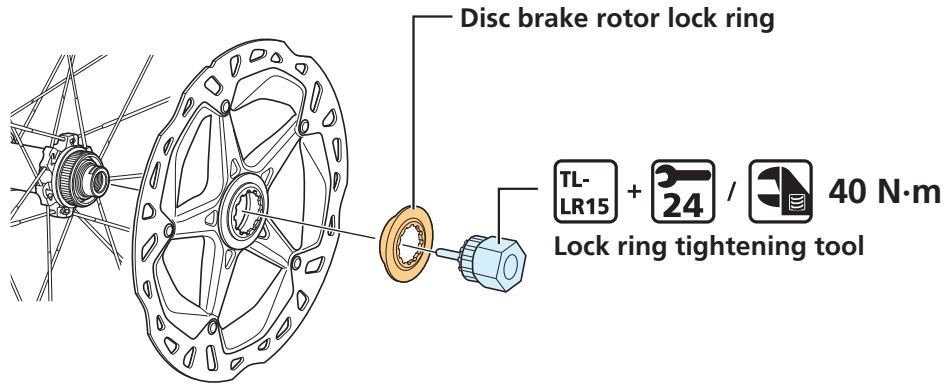

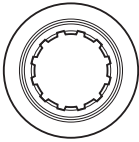
	Internal spline type
Disc brake rotor lock ring	
Lock ring tightening tool	TL-LR15 and 24 mm hub spanner / adjustable wrench

# Removing the disc brake rotor

Perform the removal of the disc brake rotor in the reverse order from the installation procedure.

# Maintenance

## Spoke lacing

### WH-R9270

Lace the spokes as shown in the figure.

\* Refer to the table for spoke tension value.

Number of spokes: 24

For front use (WH-R9270-C36/WH-R9270-C50)

Left side (disc brake rotor side)

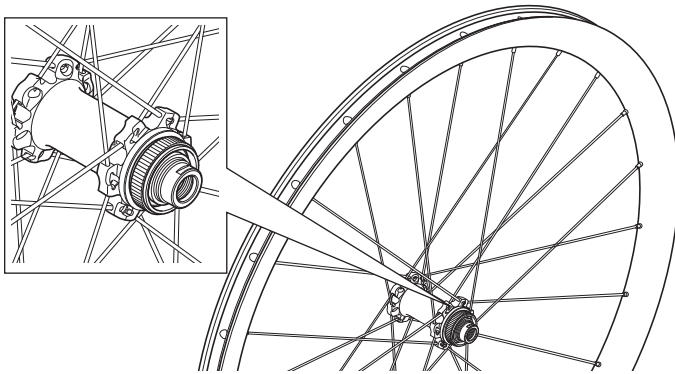

Right side

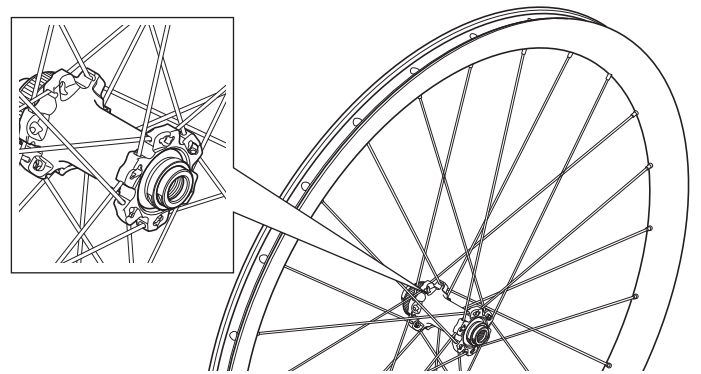

For front use (WH-R9270-C60)

Left side (disc brake rotor side)

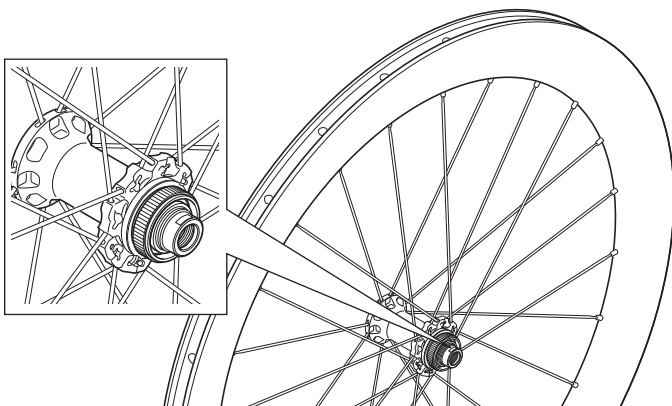

Right side

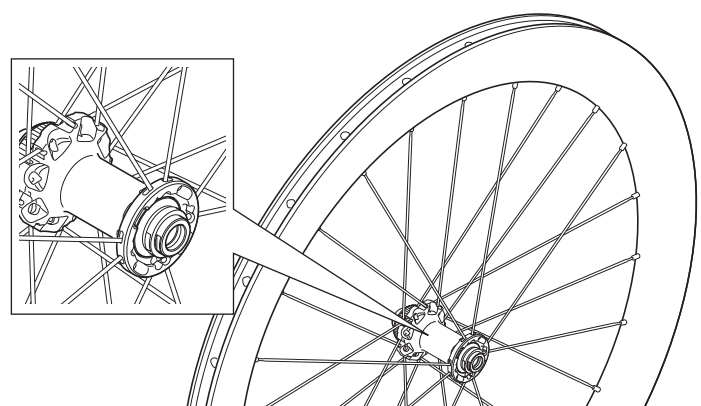

For rear use (WH-R9270-C36/WH-R9270-C50/WH-R9270-C60)

Left side (disc brake rotor side)

Right side (sprocket side)

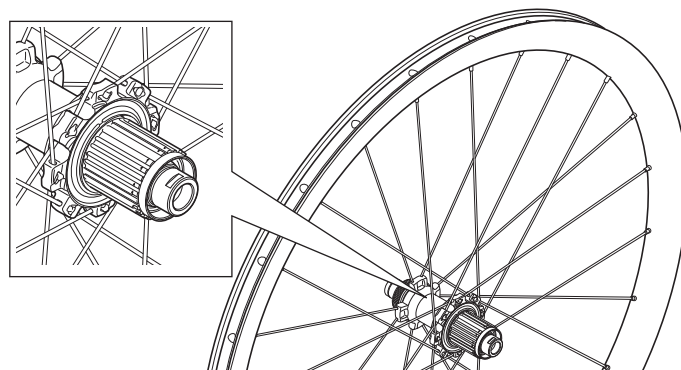
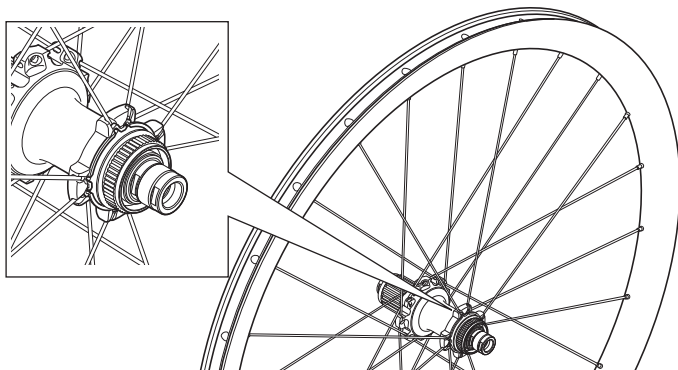

Spoke tension value

		Left side (disc brake rotor side)	Right side
WH-R9270-C36-TU	For front	950 - 1,250 N	600 - 770 N
	For rear	810 - 1,110 N	850 - 1,150 N
WH-R9270-C50-TU	For front	950 - 1,250 N	600 - 770 N
	For rear	810 - 1,110 N	850 - 1,150 N
WH-R9270-C60-HR-TU	For front	850 - 1,150 N	1,010 - 1,200 N
	For rear	810 - 1,110 N	850 - 1,150 N
WH-R9270-C36-TL	For front	1,100 - 1,400 N	700 - 860 N
	For rear	906 - 1,206 N	950 - 1,250 N
WH-R9270-C50-TL	For front	1,050 - 1,350 N	660 - 840 N
	For rear	906 - 1,206 N	950 - 1,250 N
WH-R9270-C60-HR-TL	For front	950 - 1,250 N	1,131 - 1,311 N
	For rear	906 - 1,206 N	950 - 1,250 N

## WH-R8170

Lace the spokes as shown in the figure.

\* Refer to the table for spoke tension value.

Number of spokes: 24

For front

Left side (disc brake rotor side)

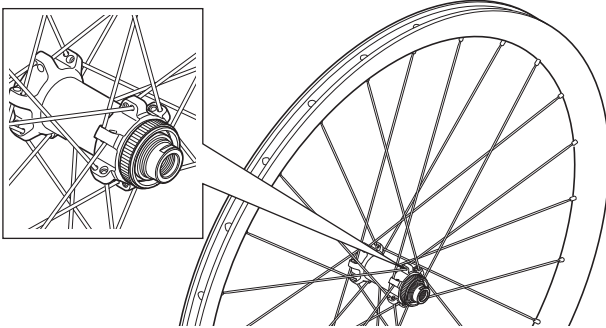

Right side

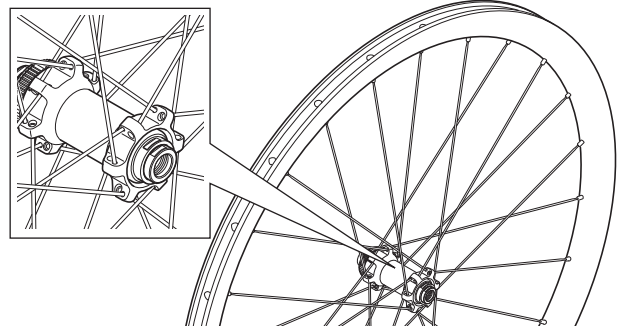

For rear

Left side (disc brake rotor side)

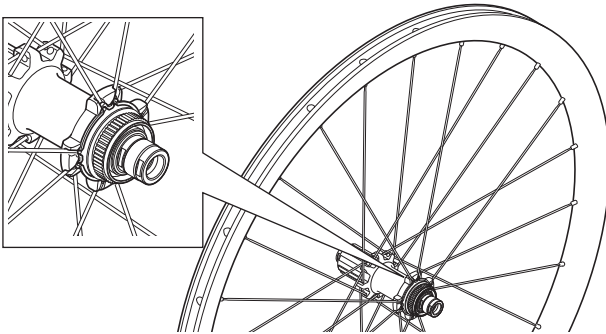

Right side (sprocket side)

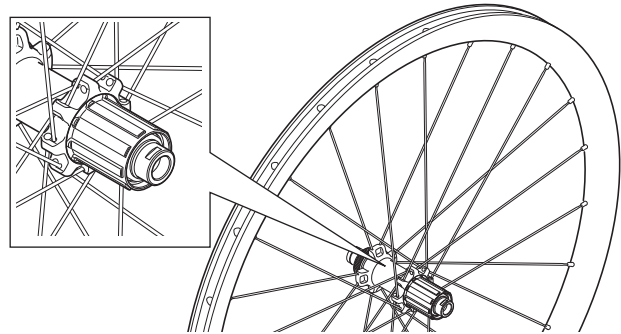

Spoke tension value

		Left side (disc brake rotor side)	Right side
WH-R8170-36-TL	For front	1,100 - 1,400 N	695 - 885 N
	For rear	885 - 1,165 N	950 - 1,250 N
WH-R8170-50-TL	For front	1,050 - 1,350 N	665 - 855 N
	For rear	885 - 1,165 N	950 - 1,250 N
WH-R8170-60-TL	For front	1,050 - 1,350 N	665 - 855 N
	For rear	885 - 1,165 N	950 - 1,250 N

## WH-RS710

Lace the spokes as shown in the figure.

\* Refer to the table for spoke tension value.

Number of spokes: 24

For front

Left side (disc brake rotor side)

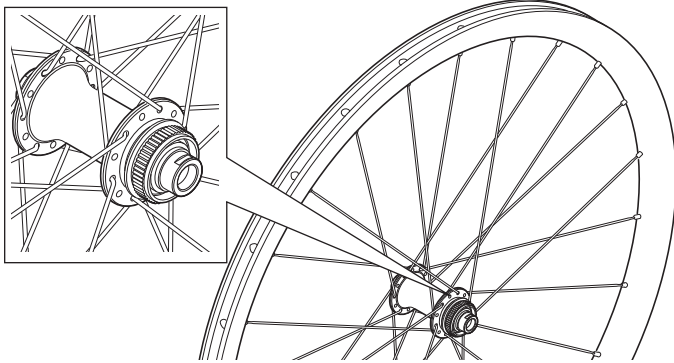

Right side

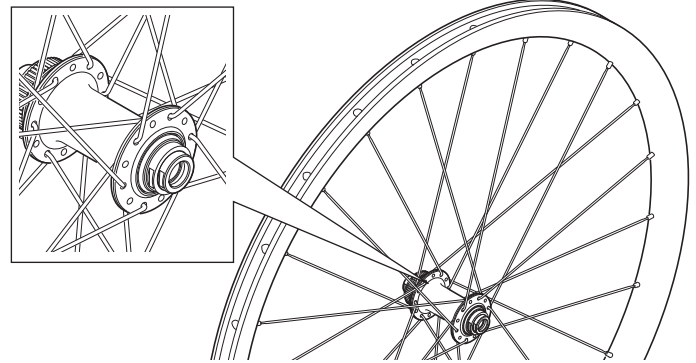

For rear

Left side (disc brake rotor side)

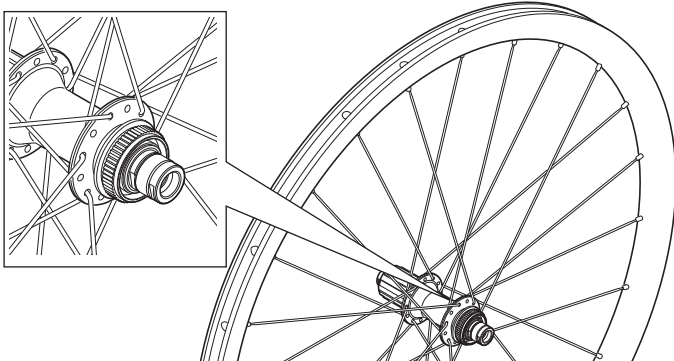

Right side (sprocket side)

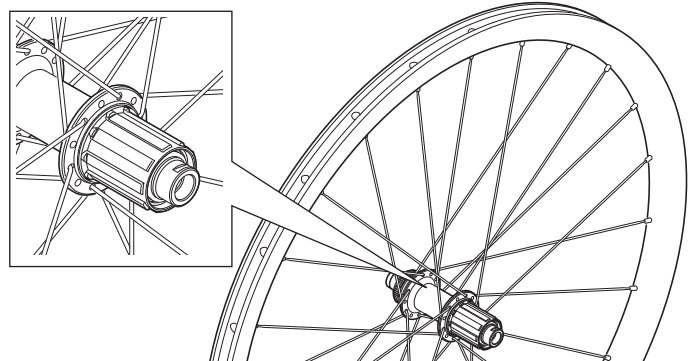

**Spoke tension value**

		Left side (disc brake rotor side)	Right side
WH-RS710-C32-TL	For front	1,100 - 1,400 N	700 - 1,000 N
	For rear	620 - 920 N	1,100 - 1,400 N
WH-RS710-C46-TL	For front	1,100 - 1,400 N	700 - 1,000 N
	For rear	620 - 920 N	1,100 - 1,400 N

# Replacing the spokes

Remove the tubeless tape before replacing the spokes.

(For instructions on affixing/removing tubeless tape, refer to “Replacing tubeless tape”.)

## WH-R9270

## ▶ Front

**1. Remove the spokes.**

When replacing the outer spoke, remove the inner spoke first.

When installing, reverse the procedure.

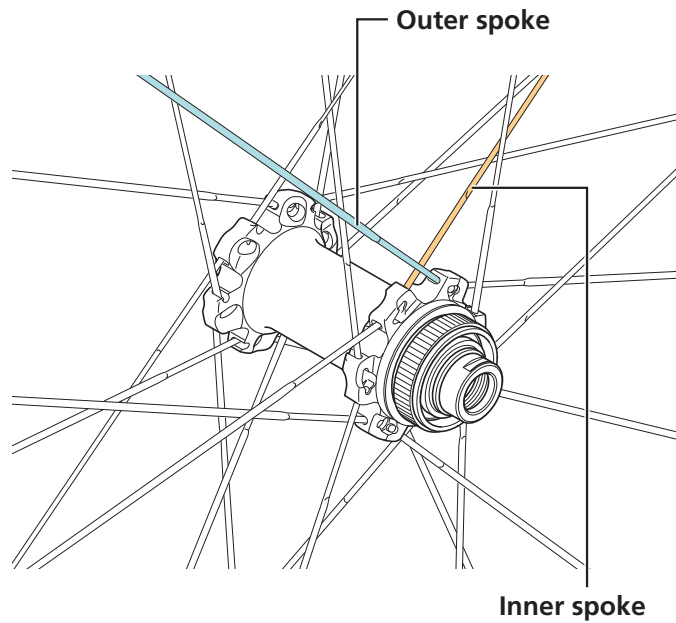
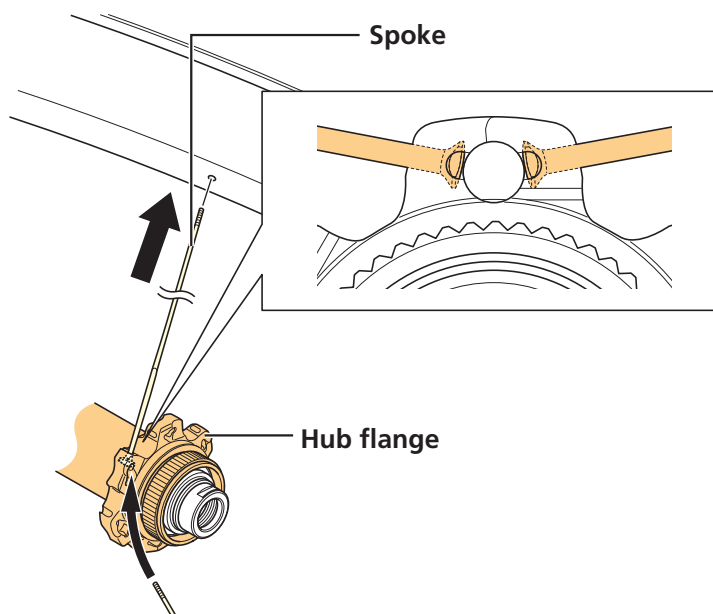
**2. Insert the spoke through the hole in the hub flange.**

**NOTICE**

- Pay attention to the direction of the flat surface of the spoke to set it correctly as shown in the figure.

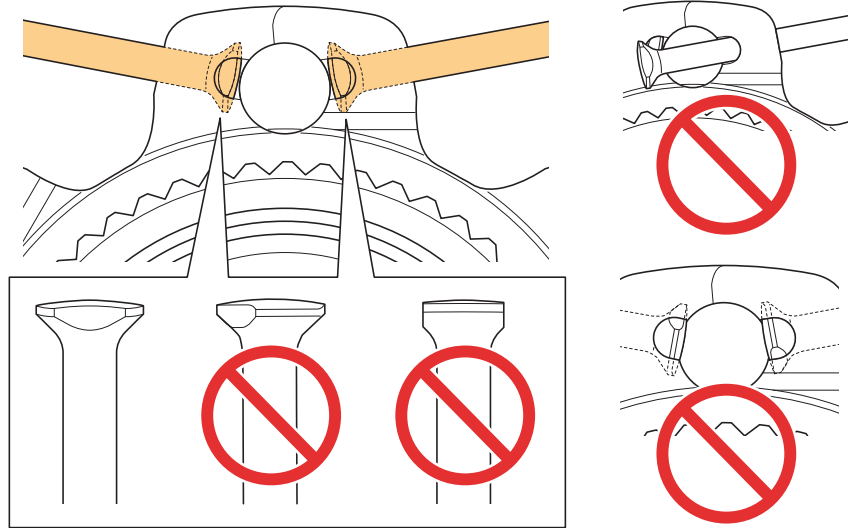

### 3. Attach the nipple and tighten the spoke to the specified tension.

Secure the flat part of the spoke with the TL-WHR92 SHIMANO original tool to stop the spoke from turning.

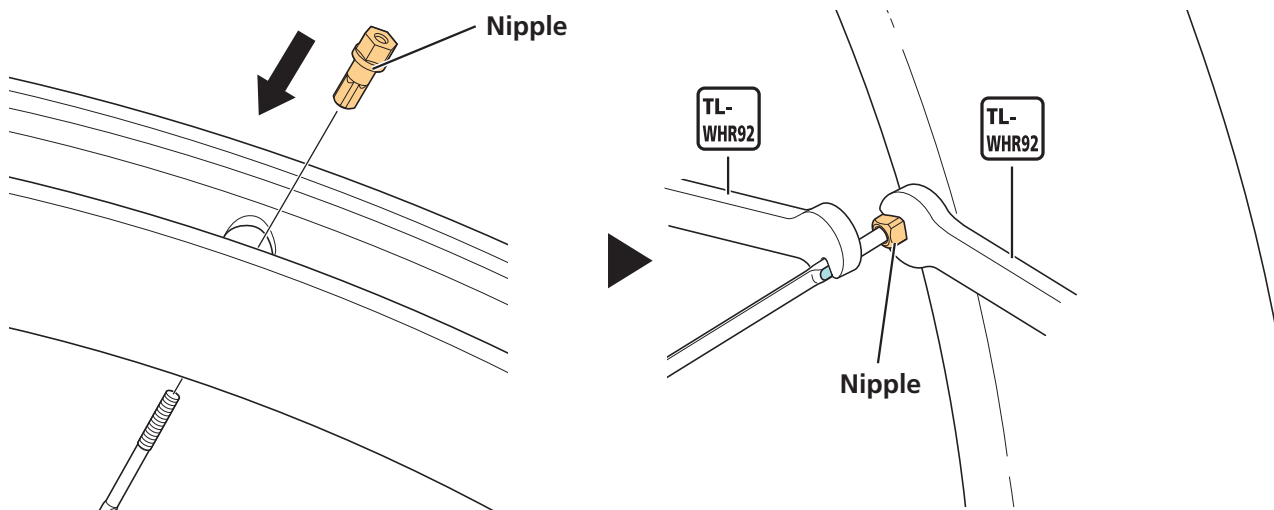

## ▶ Rear (right side)

### 1. Remove the spokes.

When replacing intersecting spokes, remove two inner spokes first.  
When installing, reverse the procedure.

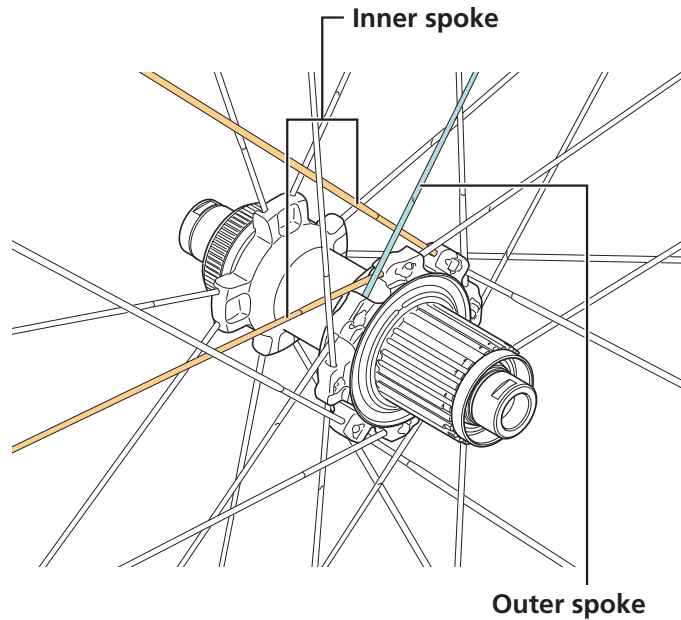

### 2. Insert the spoke through the hole in the hub flange.

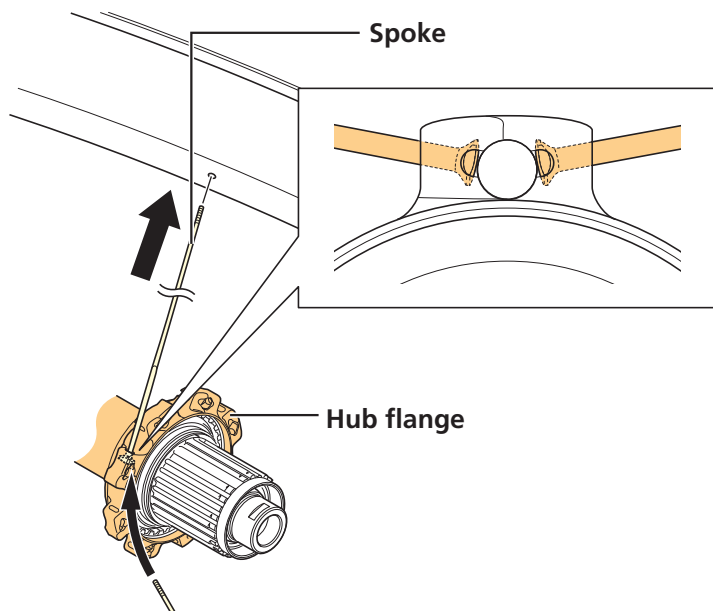

**NOTICE**

- Pay attention to the direction of the flat surface of the spoke to set it correctly as shown in the figure.

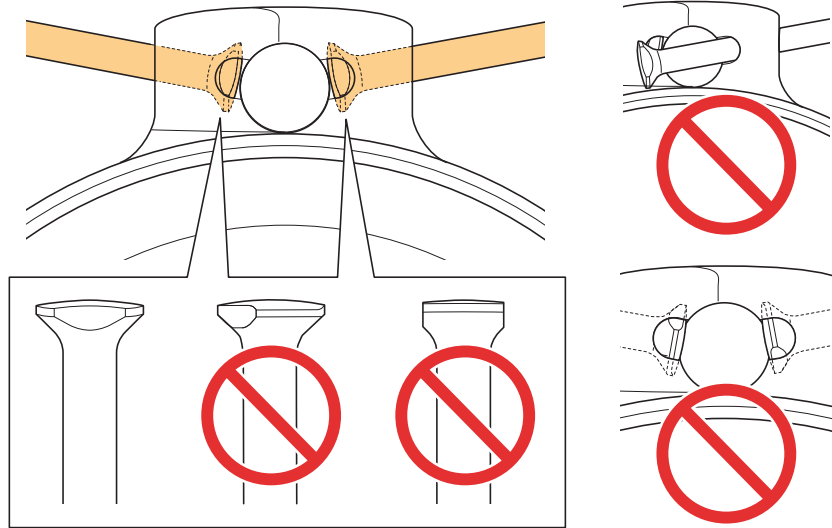

### 3. Attach the nipple and tighten the spoke to the specified tension.

Refer to step 3 of "Front" in "Replacing the spokes."

#### ▶ Rear (left side)

### 1. Remove the spoke cover using a tool such as a slotted screwdriver.

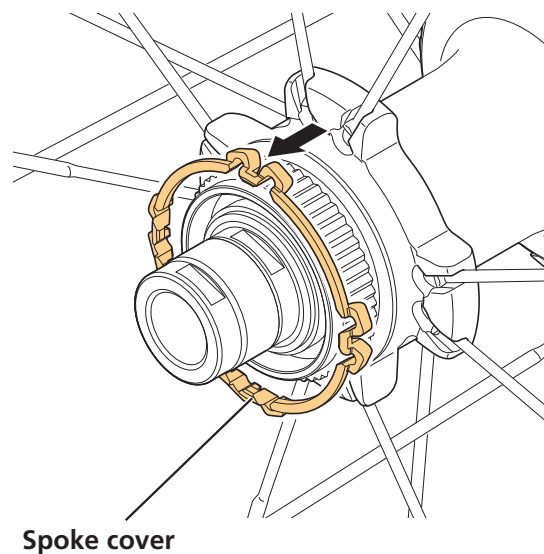

## 2. Remove the spoke to replace.

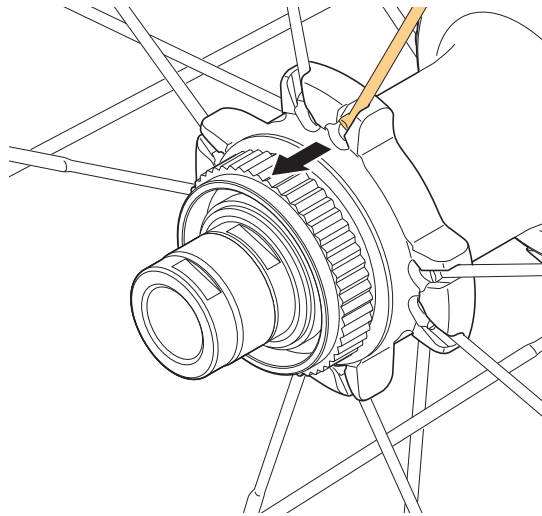

## 3. Insert the new spoke into the groove on the hub flange as shown in the figure.

Note the installation direction of the spoke.

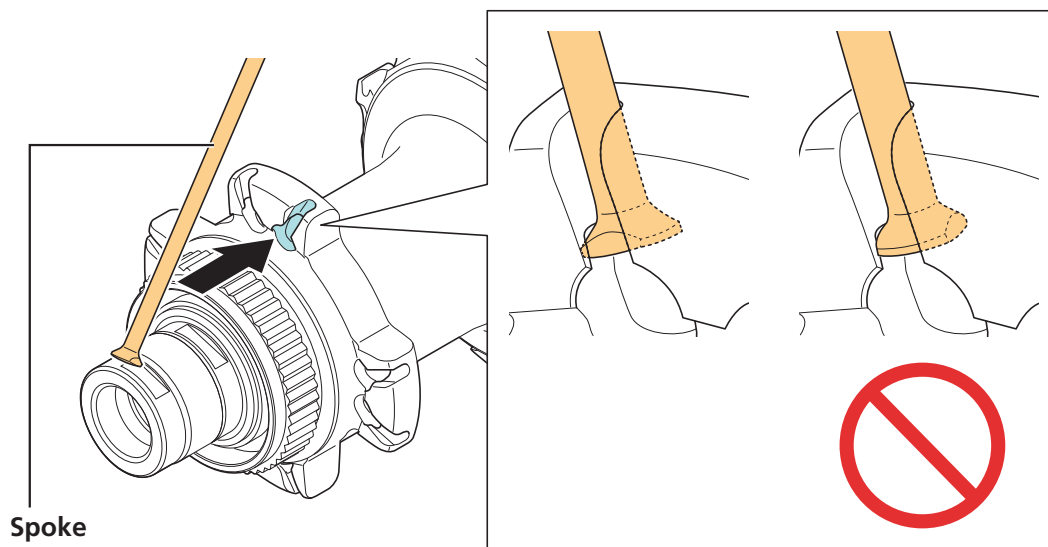

#### 4. Attach the nipple and tighten the spoke to the specified tension.

Secure the flat part of the spoke with the TL-WHR92 SHIMANO original tool to stop the spoke from turning.

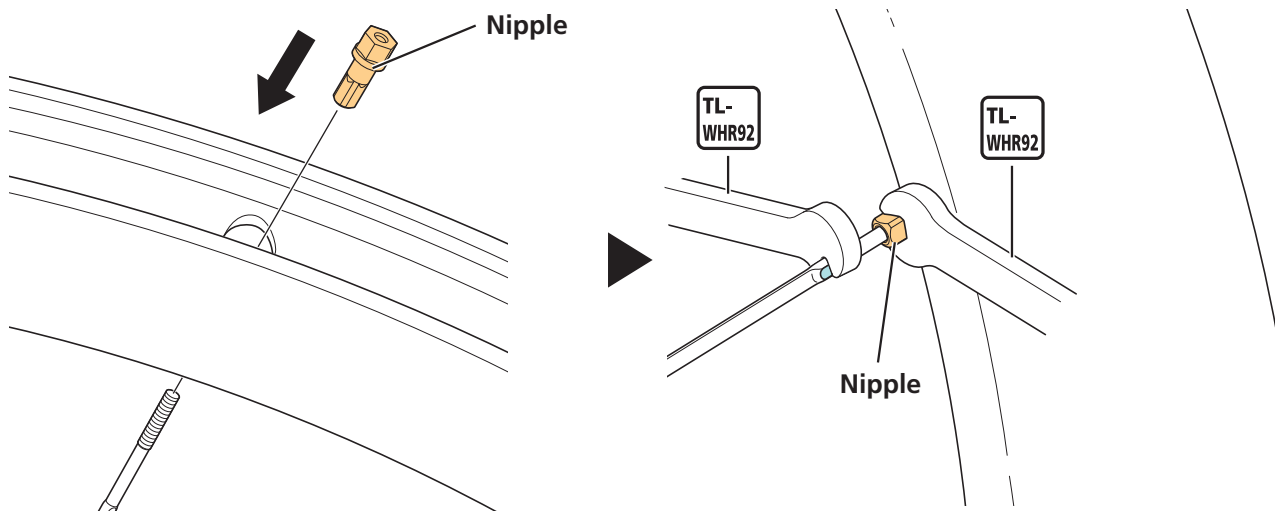

#### 5. Finally, reinstall the spoke cover.

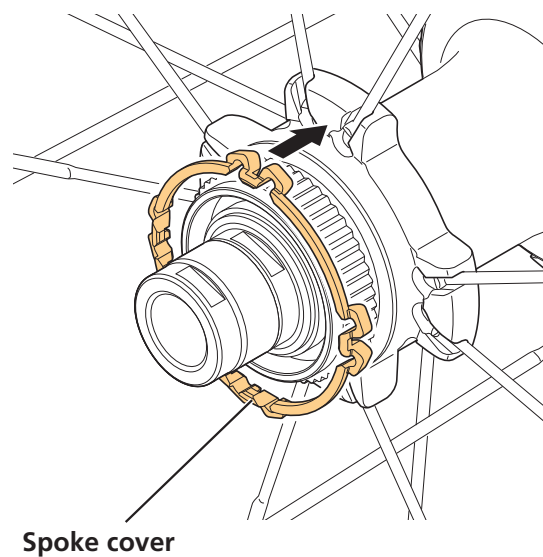

**NOTICE**

- Note the location to press when installing the spoke cover. Otherwise the spoke cover may be damaged.

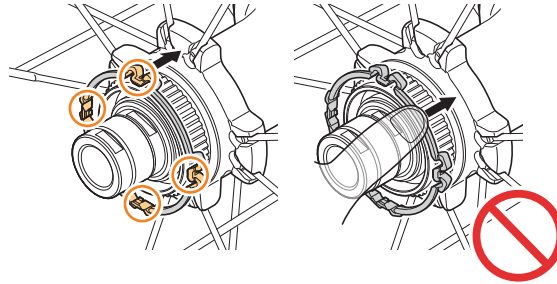
**WH-R8170****▶ Front (right side, left side), rear (right side)**

- 1. Remove the spoke to replace.**
- 2. Insert the spoke through the hole in the hub flange.**

Set the spoke onto the hub flange as shown in the figure.

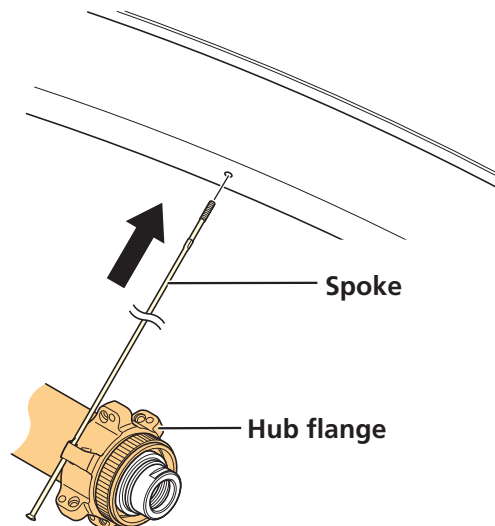

### 3. Attach the nipple and tighten the spoke to the specified tension.

Secure the flat part of the spoke with the TL-WHR92 SHIMANO original tool to stop the spoke from turning.

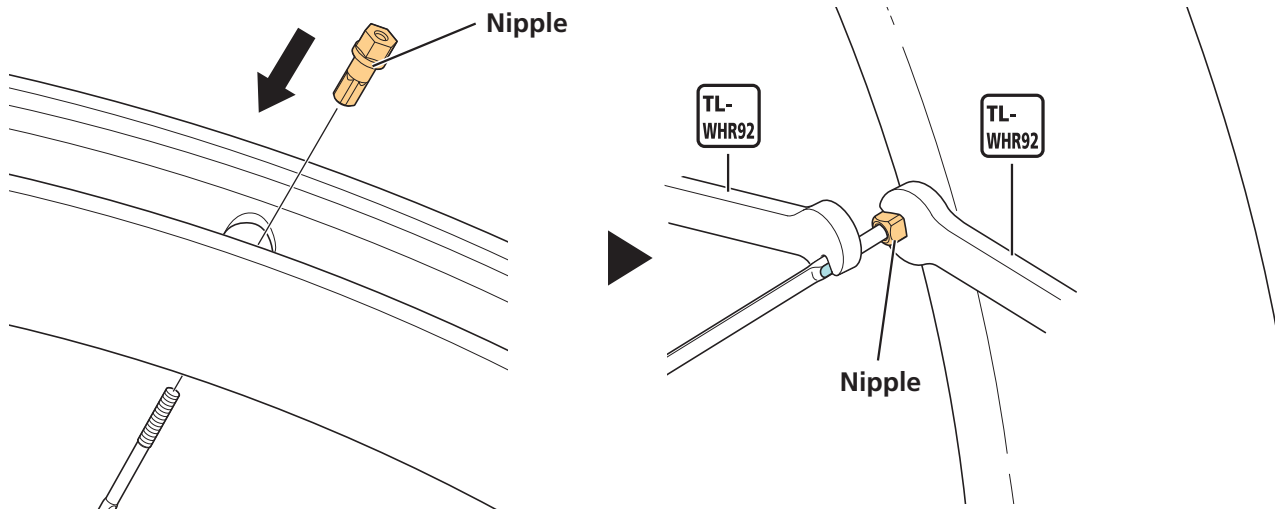

### ▶ Left side (rear)

#### 1. Remove the spoke cover using a tool such as a slotted screwdriver.

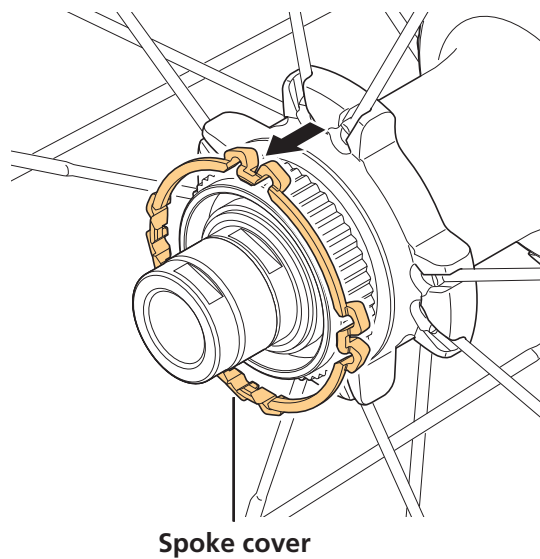

## 2. Remove the spoke to replace.

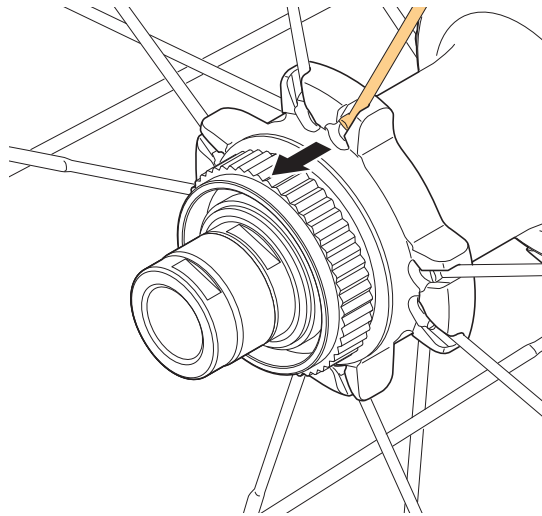

## 3. Insert the new spoke into the groove on the hub flange as shown in the figure.

Note the installation direction of the spoke.

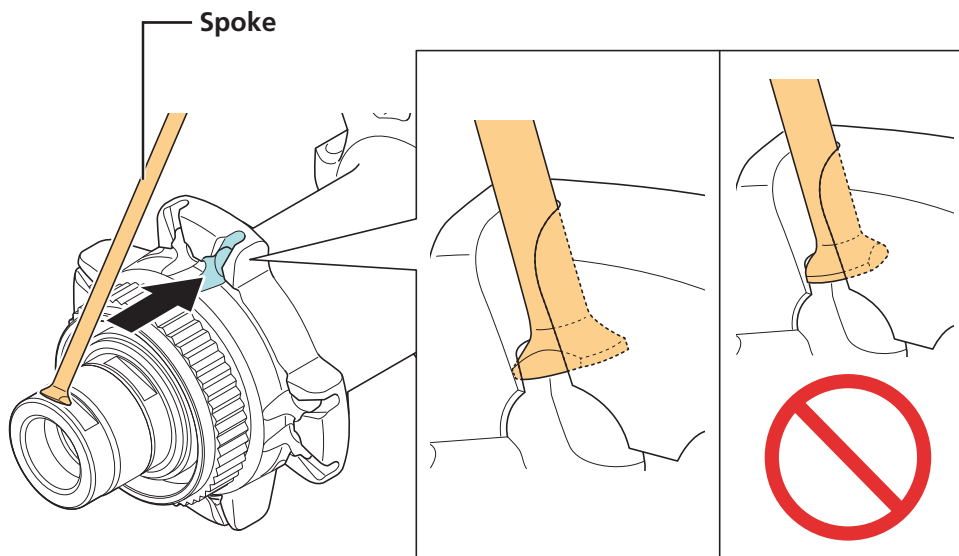

#### 4. Attach the nipple and tighten the spoke to the specified tension.

Secure the flat part of the spoke with the TL-WHR92 SHIMANO original tool to stop the spoke from turning.

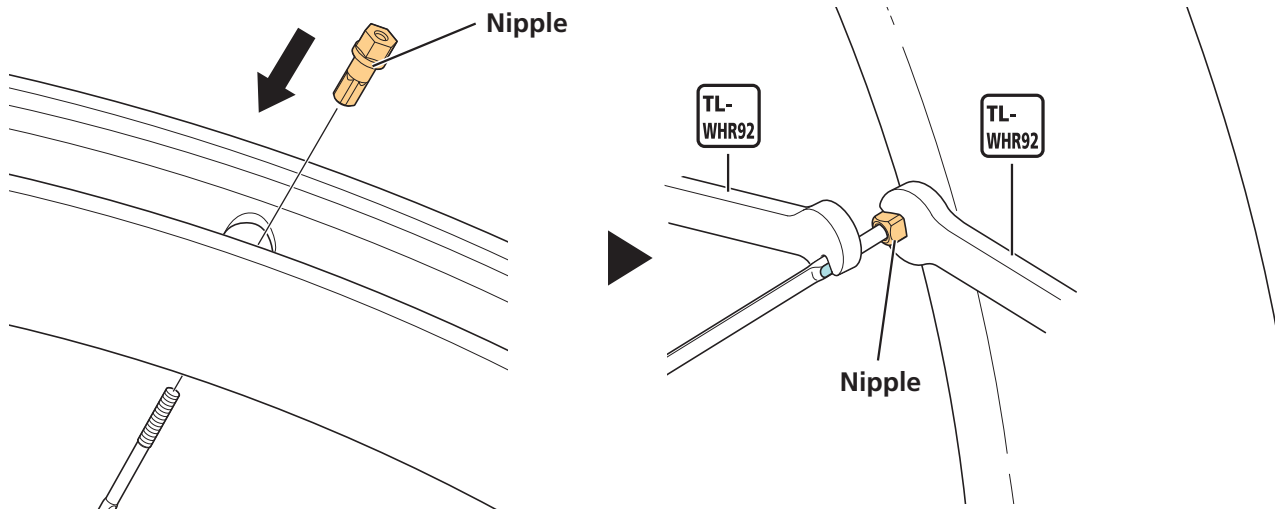

#### 5. Finally, reinstall the spoke cover.

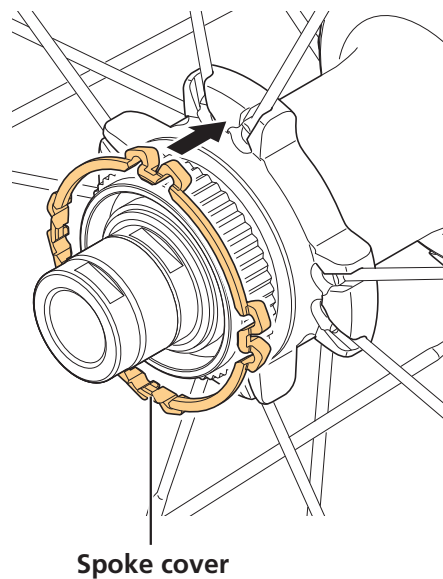

**NOTICE**

- Note the location to press when installing the spoke cover. Otherwise the spoke cover may be damaged.

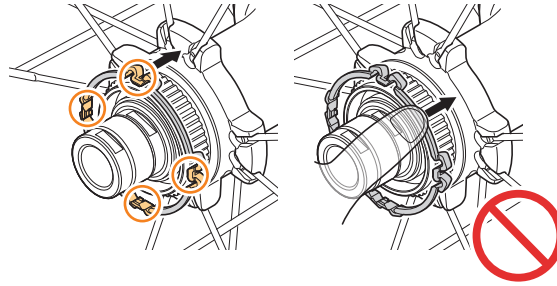
**WH-RS710**

- 1. Remove the spoke to replace.**
- 2. Insert the spoke through the hole in the hub flange.**

Set the spoke onto the hub flange as shown in the figure.

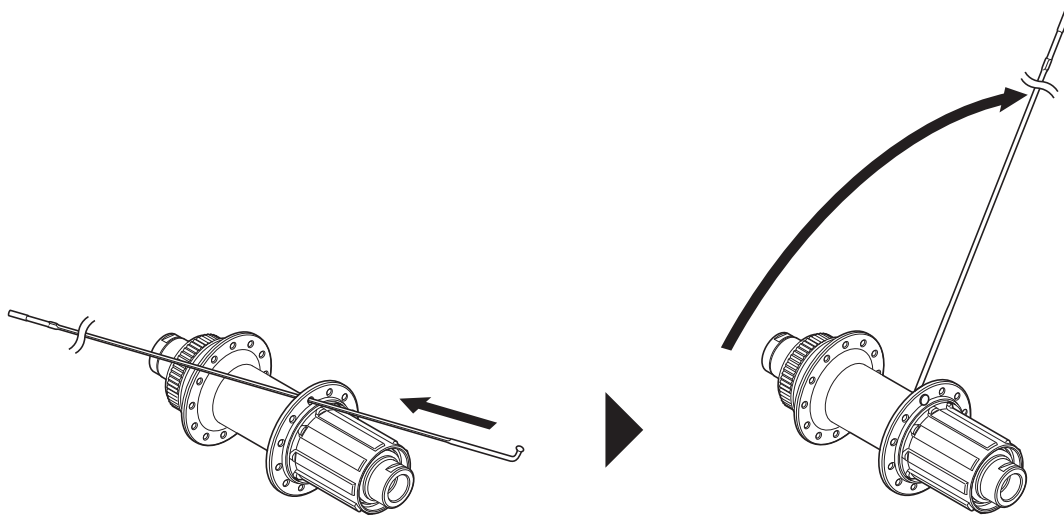

### 3. Attach the nipple and tighten the spoke to the specified tension.

Secure the flat part of the spoke with the TL-WHR92 SHIMANO original tool to stop the spoke from turning.

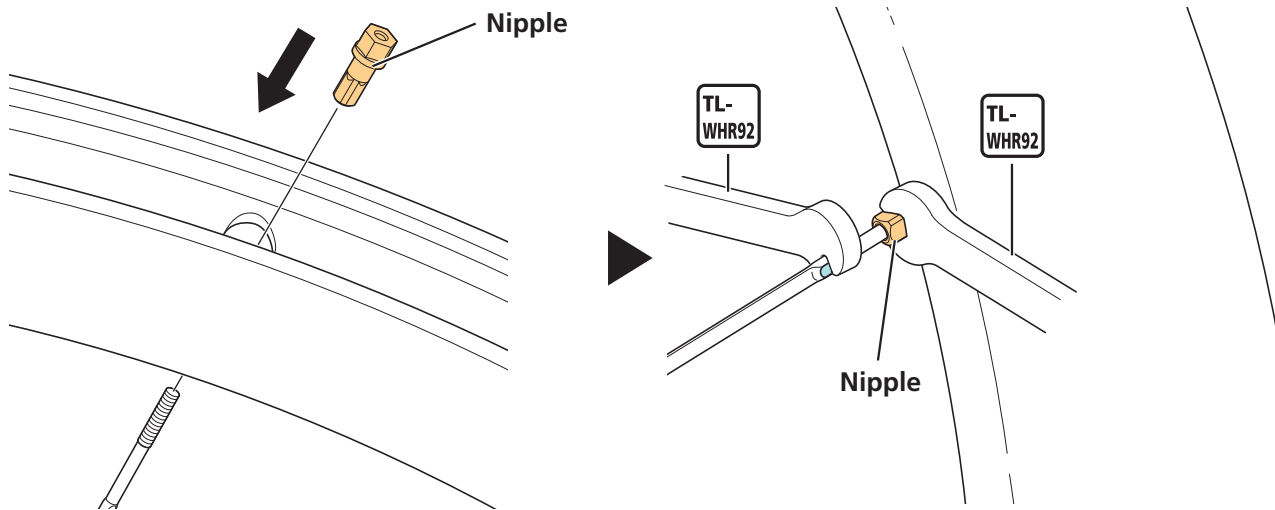

## Replacing tubeless tape

### Important safety information

#### ⚠ CAUTION

- Be sure to use tubeless tape when using these wheels.
- Do not use tape other than genuine SHIMANO tubeless tape. Otherwise, a sudden puncture may occur, and you may fall off the bicycle.

### 1. If sealant was used in the tire, use a clean rag to wipe away any residual sealant from the rim and tape.

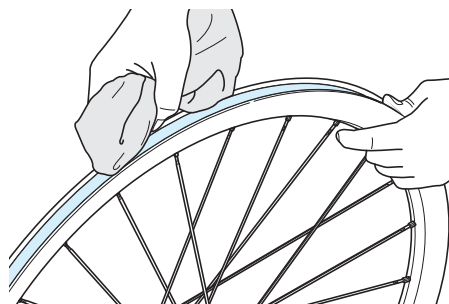

## 2. Remove the tubeless tape.

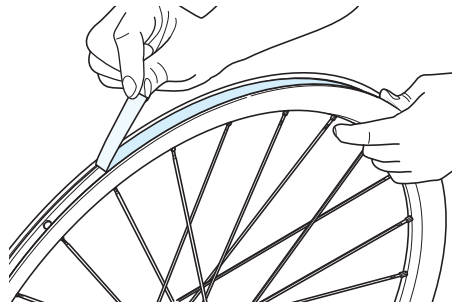

### NOTICE

- Tubeless tape cannot be reused. After removing tubeless tape, always replace it with new tape.
- Use a tubeless tape matching the rim inner width.
- Use genuine SHIMANO tubeless tape to prevent punctures and other possible damage.

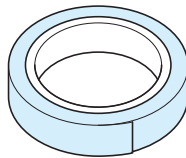

Tubeless tape

## 3. Use a clean rag to wipe off any residue, sealant or dirt from the surface where the tubeless tape will be affixed.

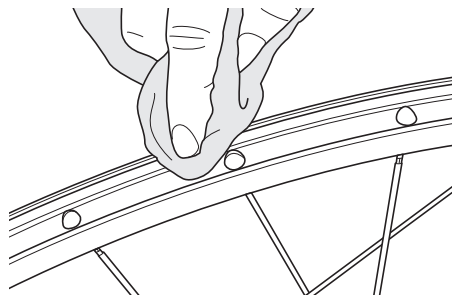

## 4. Affix new tubeless tape.

Start affixing the tubeless tape from the opposite side of the valve.

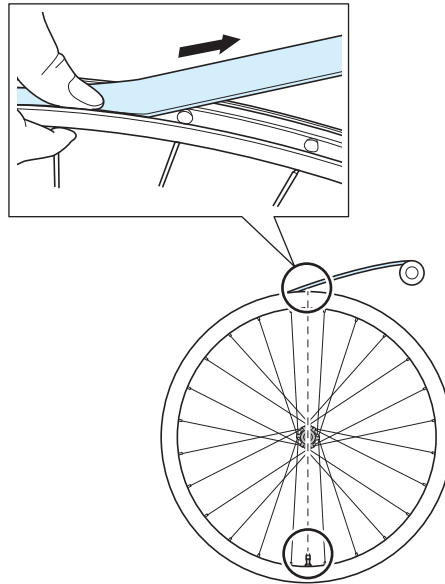

### TECH TIPS

- Do not use a tool to affix the tape, as it may cause the tape to tear.
- Pull on the tape to give it some tension when affixing it in order to ensure it sits cleanly in the rim.
- When affixing the tape, align the center of the tape with the center of the rim, not off to one side, as shown in the figure.

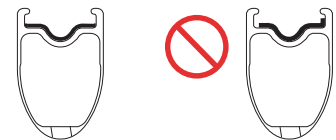

## 5. Securely attach both ends of the tape to the rim.

\* Overlap the ends of the tape by approximately 10 cm.

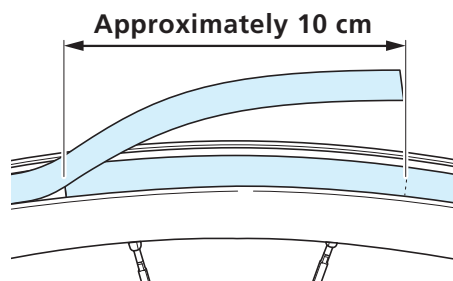

## 6. Punch a pilot hole in the valve hole section, then attach the valve.

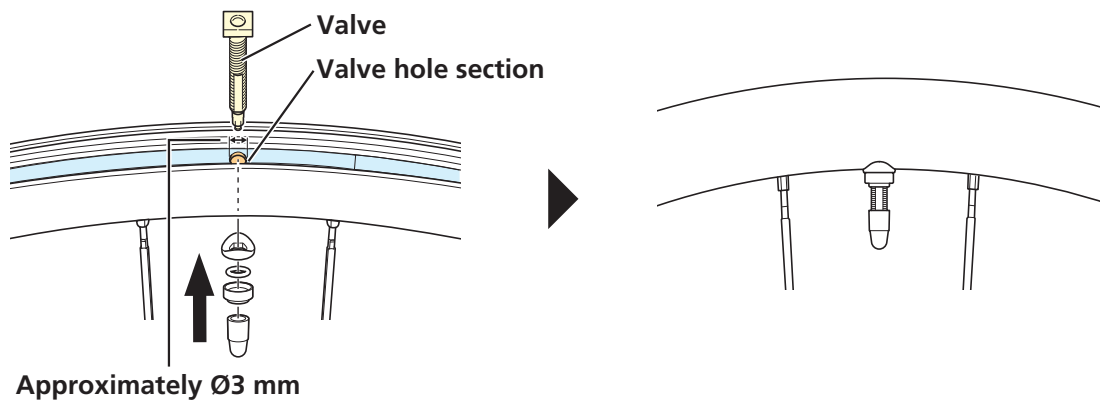

### NOTICE

- Note the direction of the valve.

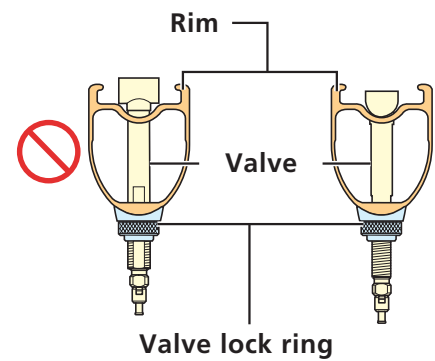

- When tightening the valve lock ring, check that the valve does not turn together with the valve lock ring.

# Front hub

## Disassembly

### 1. Loosen the lock nut on the double-lock section on the right side of the hub body.

The hub cannot be disassembled from the left side of the hub body (the disc brake rotor side).

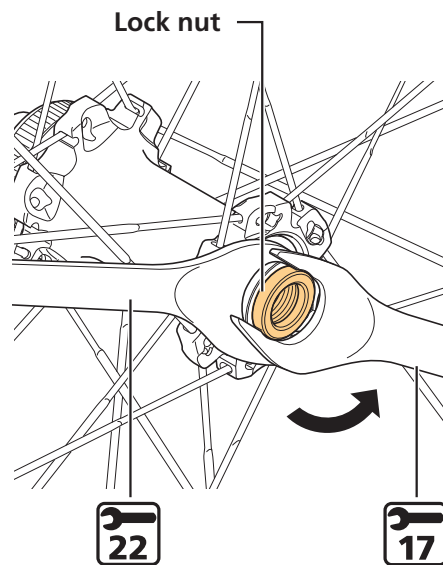

#### NOTICE

- Be careful not to apply excessive torque to the hub axle left side when loosening the lock nut. The hub axle may be damaged. When securing the beveled area of the left side of the hub axle with a hub spanner, be careful not to apply excessive force.

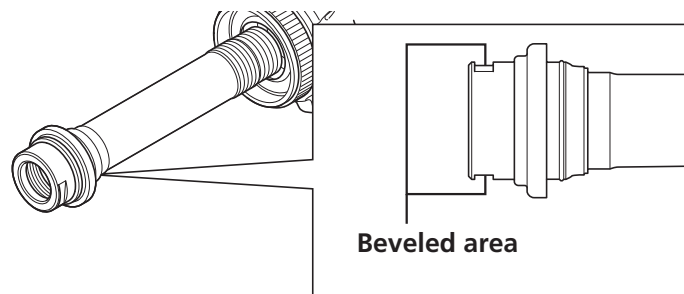

**2.** The unit can be disassembled as shown in the figure. Apply grease to the indicated parts at periodic intervals.

WH-R9270

Apply grease:  
Premium Grease  
(Y04110000)  
Number of balls: 14  
Ball size: 5/32"

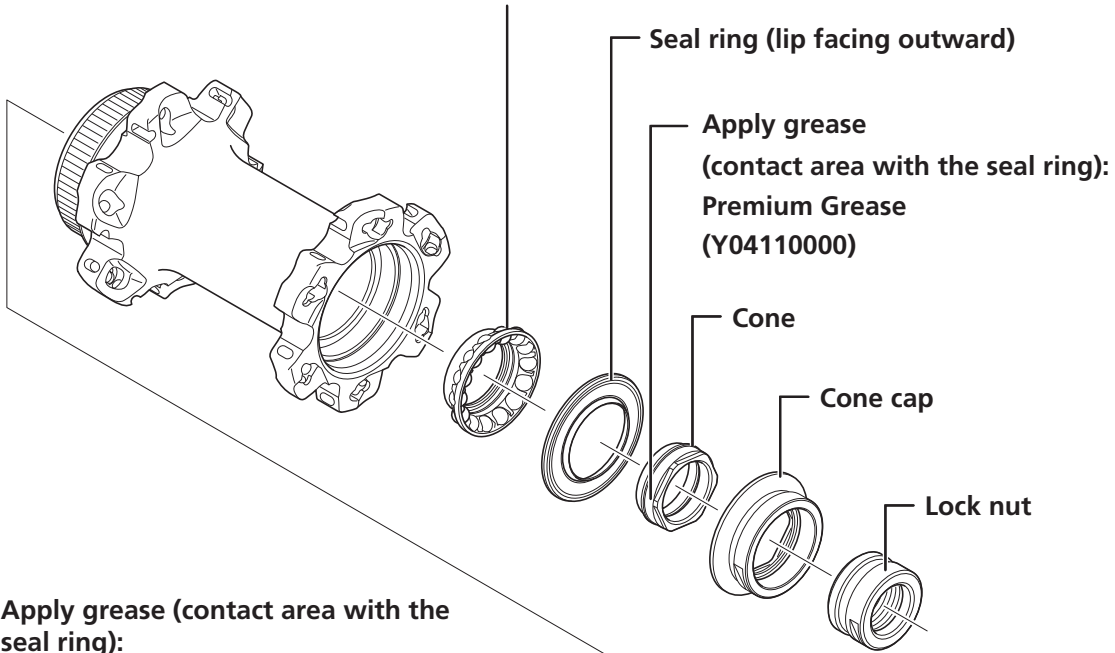

Apply grease (contact area with the seal ring):  
Premium Grease  
(Y04110000)

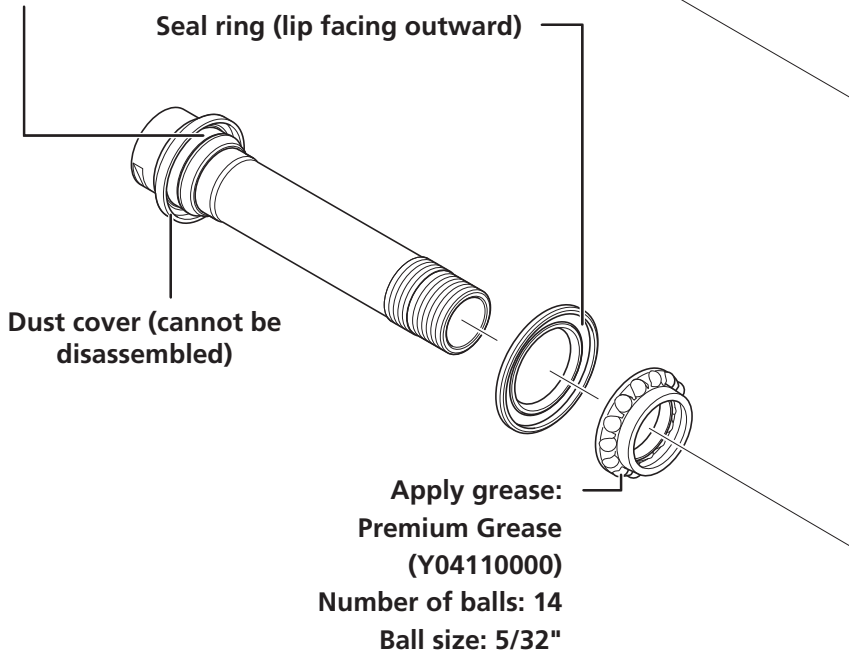

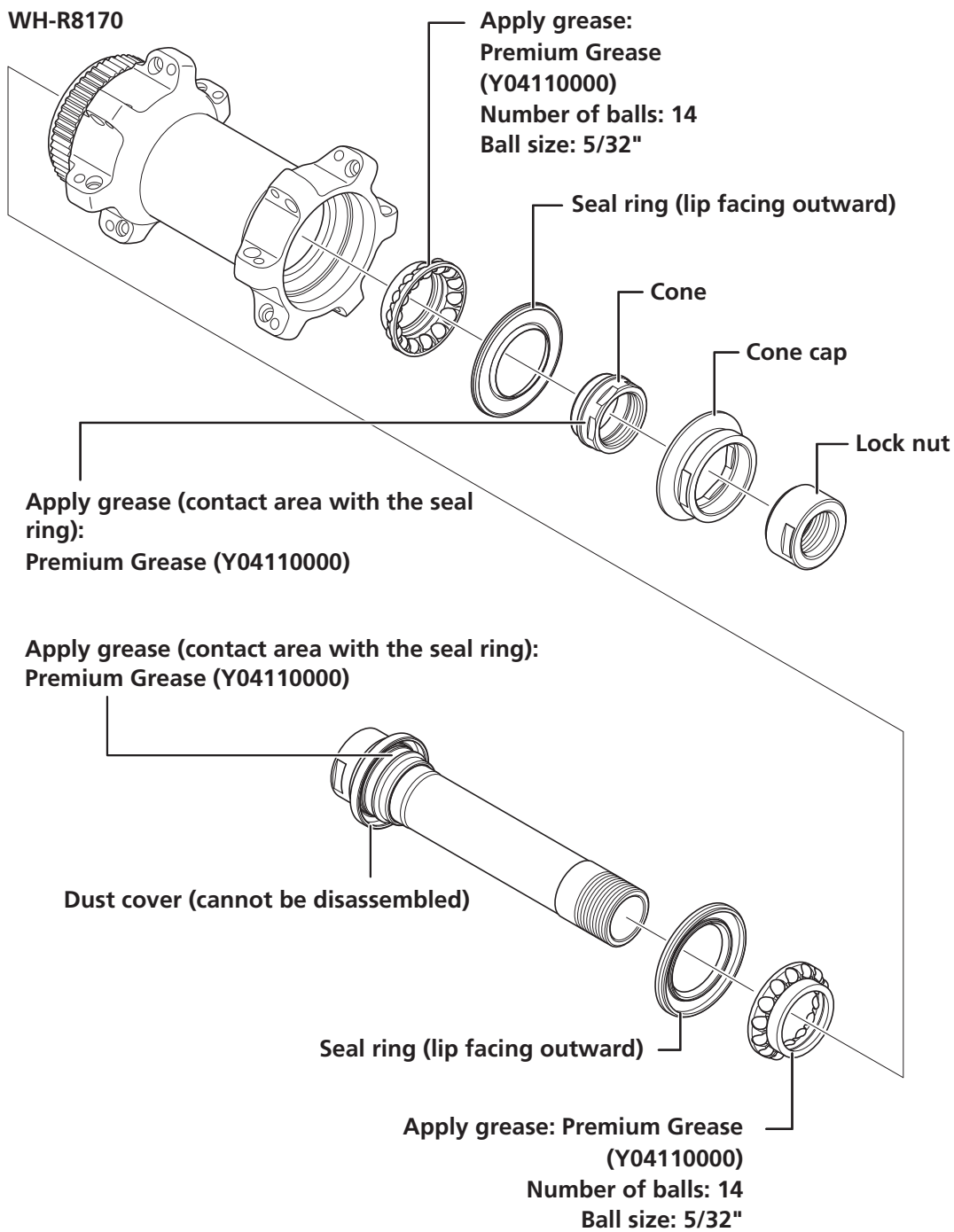

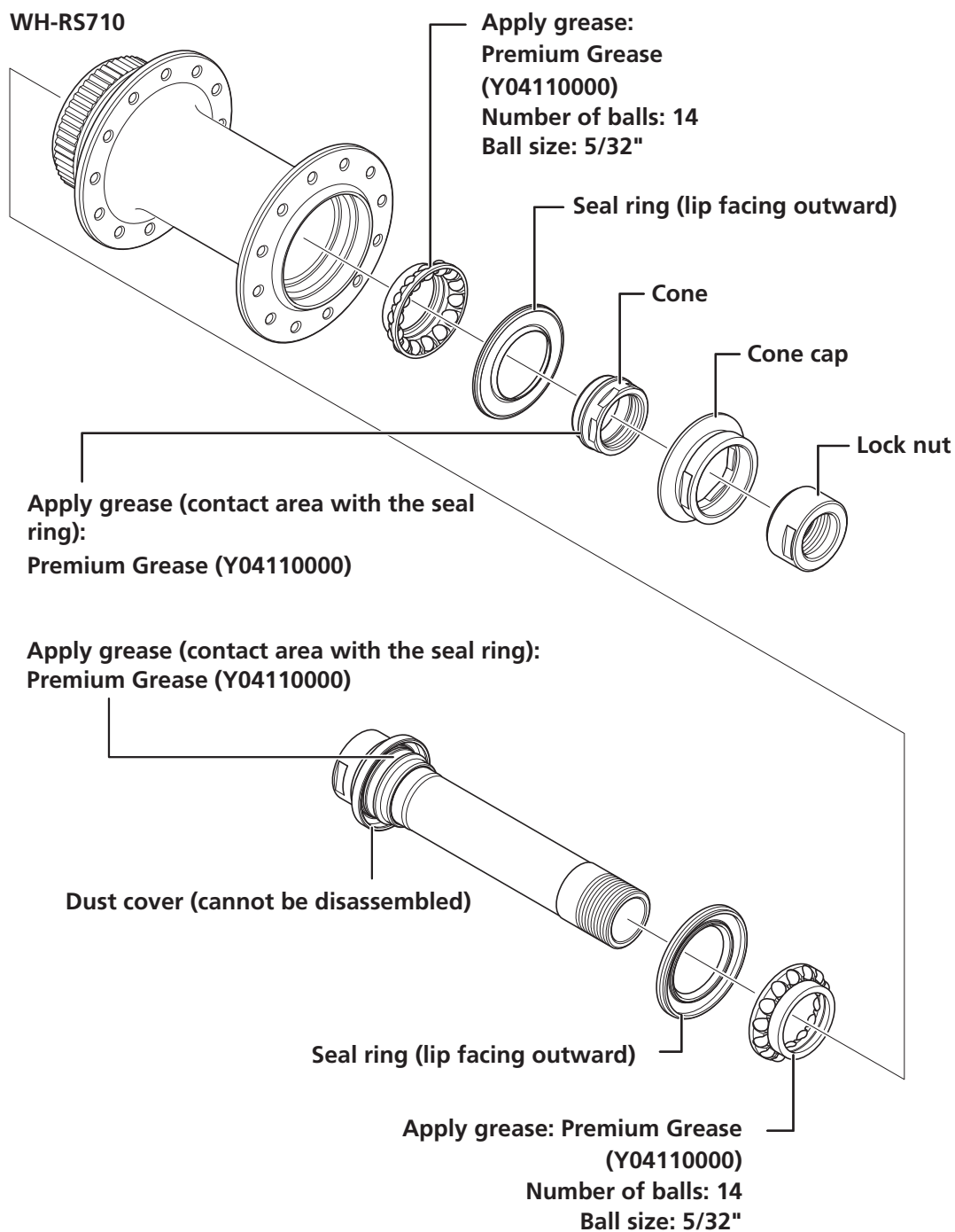

**NOTICE**

- Conduct the removal and installation of the seal very carefully so that it does not become deformed. When reinstalling the seal, check that it is facing the right way and insert it as far as it will go.

## Assembly

1. Install the hub axle from the left side of the hub body.

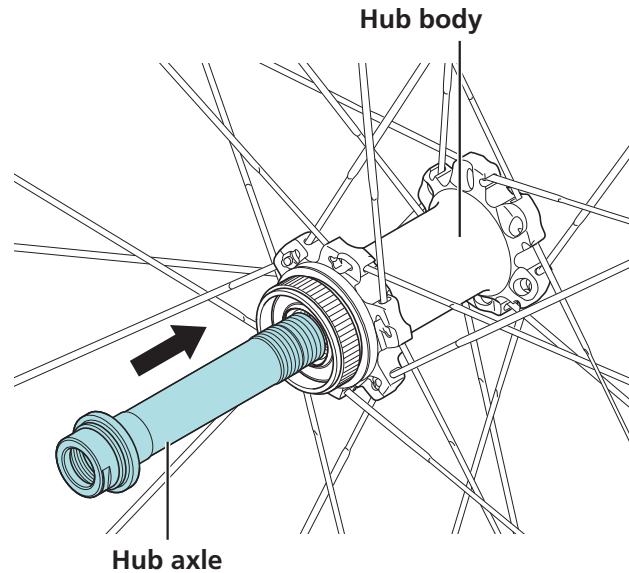

2. After installing the axle to the hub body, apply grease to the axle threads.

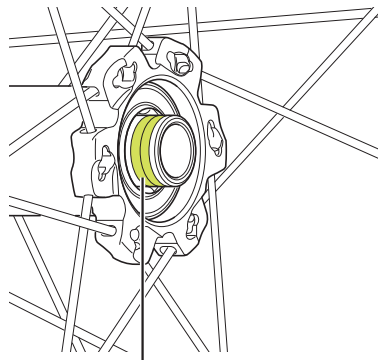

Apply grease:  
Premium Grease  
(Y04110000)

### 3. After assembling the necessary parts and adjusting the bearing preload, tighten the lock nut to double-lock the assembly.

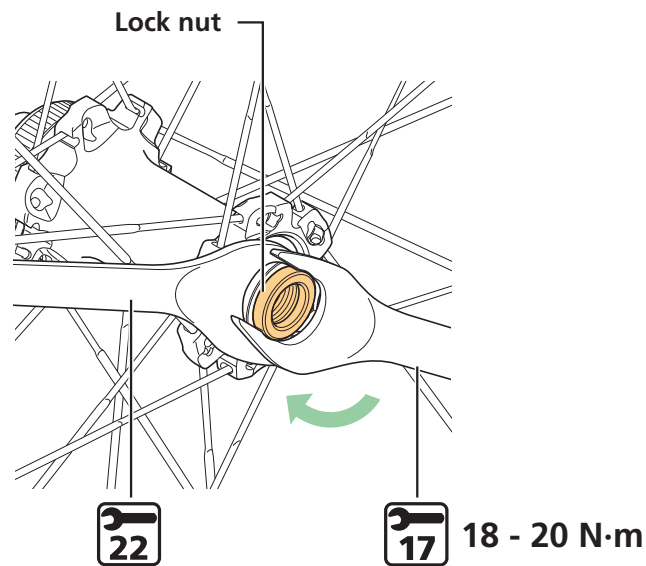

#### NOTICE

- Be careful not to apply excessive torque to the hub axle left side when tightening the lock nut. The hub axle may be damaged. When securing the beveled area of the left side of the hub axle with a hub spanner, be careful not to apply excessive force.

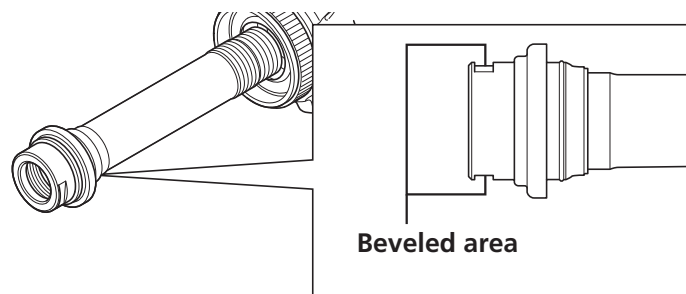

- Align the hexagonal surfaces of the cone and cone cap when installing them.

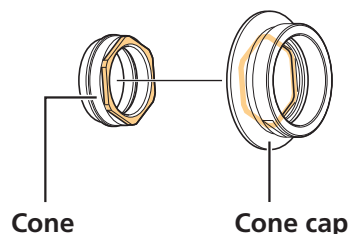

**NOTICE**

- Apply Premium Grease to the contact area with the seal ring as well as to the ball. Do not mix in any other type of grease. Only apply a thin film of grease by hand to each area.

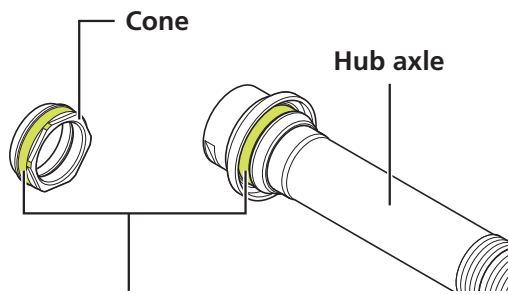

Apply grease (contact area with the seal ring):  
Premium Grease  
(Y04110000)

# Freehub

## Pre-work cautions (WH-R9270)

### ⚠ WARNING

- Except for the seal portion of (E), do not apply grease or oil to parts (A) through (G). This may lead to a malfunction in the freewheel body unit.

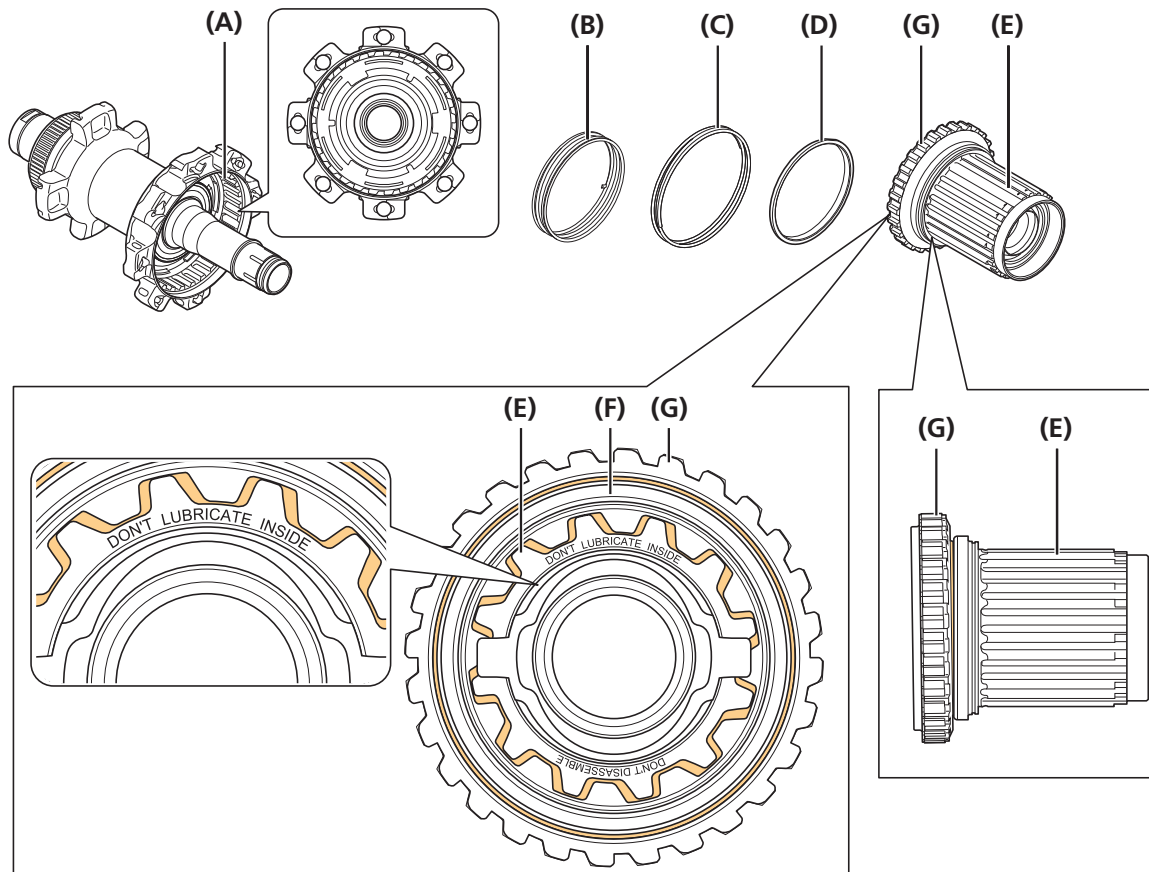

- Do not disassemble the freewheel body unit. The three parts (E), (F) and (G) form one unit (the freewheel body unit). Disassembling them may lead to a malfunction in the freewheel body unit.
- Make sure that the freewheel body unit is operating correctly before riding the bicycle by checking it several times following parts replacement or maintenance. If the freewheel body unit appears to be malfunctioning, replace it.

**⚠ WARNING**

- Apply the special grease (Seal Grease for Freehub) to the areas illustrated in the figure. Only apply a thin film by hand, and do not mix any other type of grease. If too much grease is used, the wrong grease is used, or grease is applied outside the specified areas, the freewheel body unit may malfunction.

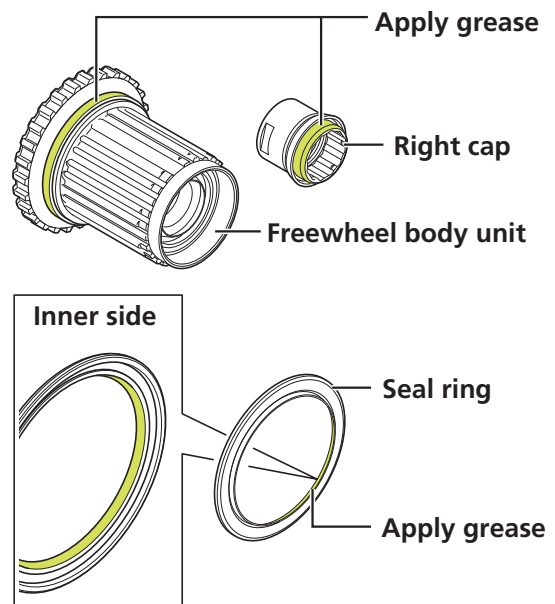
**Disassembly (WH-R9270)****1. Remove the snap ring.**

Insert the tip of a tool such as a slotted screwdriver in the split on the snap ring, and expand the snap ring to remove it.

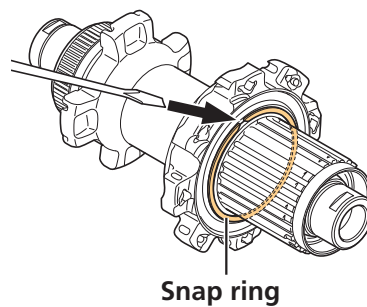

## 2. Remove the right cap by pulling it outwards off the end of the hub axle.

Do not try to unthread or put any angular load on the cap. Doing so may cause damage.



### TECH TIPS

- If you cannot remove the right cap, use an additional 22 mm hub spanner as a lever to help pull it off, as shown in the figure. Ensure the 17 mm hub spanner is horizontal and firmly seated in the flats of the right cap.

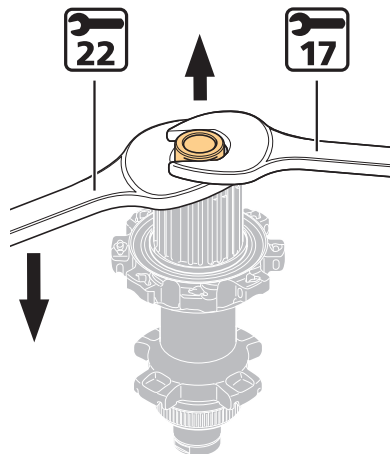

### 3. Remove the freewheel body unit.

The outer dust cover, seal ring, and spacer can be removed at the same time by pulling on the freewheel body.

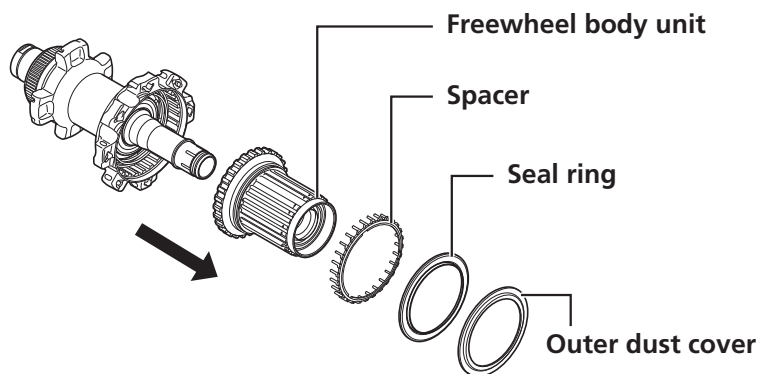

### 4. Loosen the lock nut on the double-lock section on the left side of the hub body.

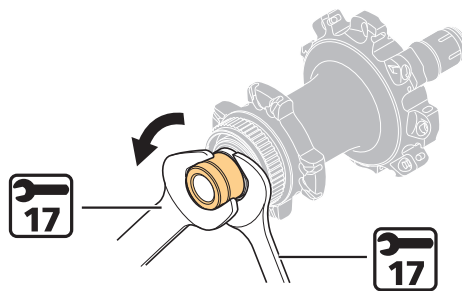

### 5. Remove the lock nut, cone, and seal ring.

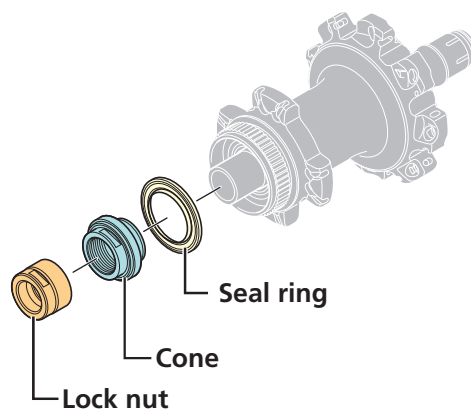

**6. Remove the hub axle from the right side of the hub body.**

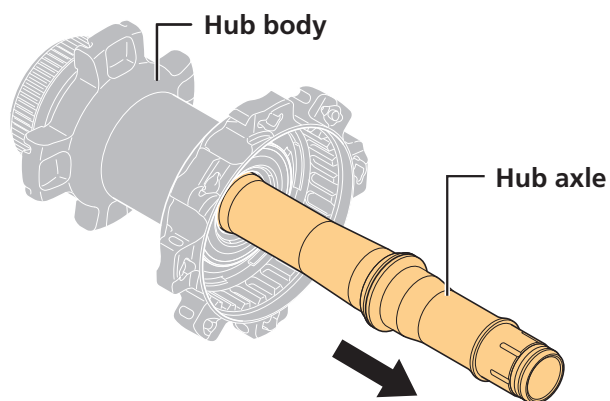

**7.** The unit can be disassembled as shown in the figure. Apply grease to the indicated parts at periodic intervals.

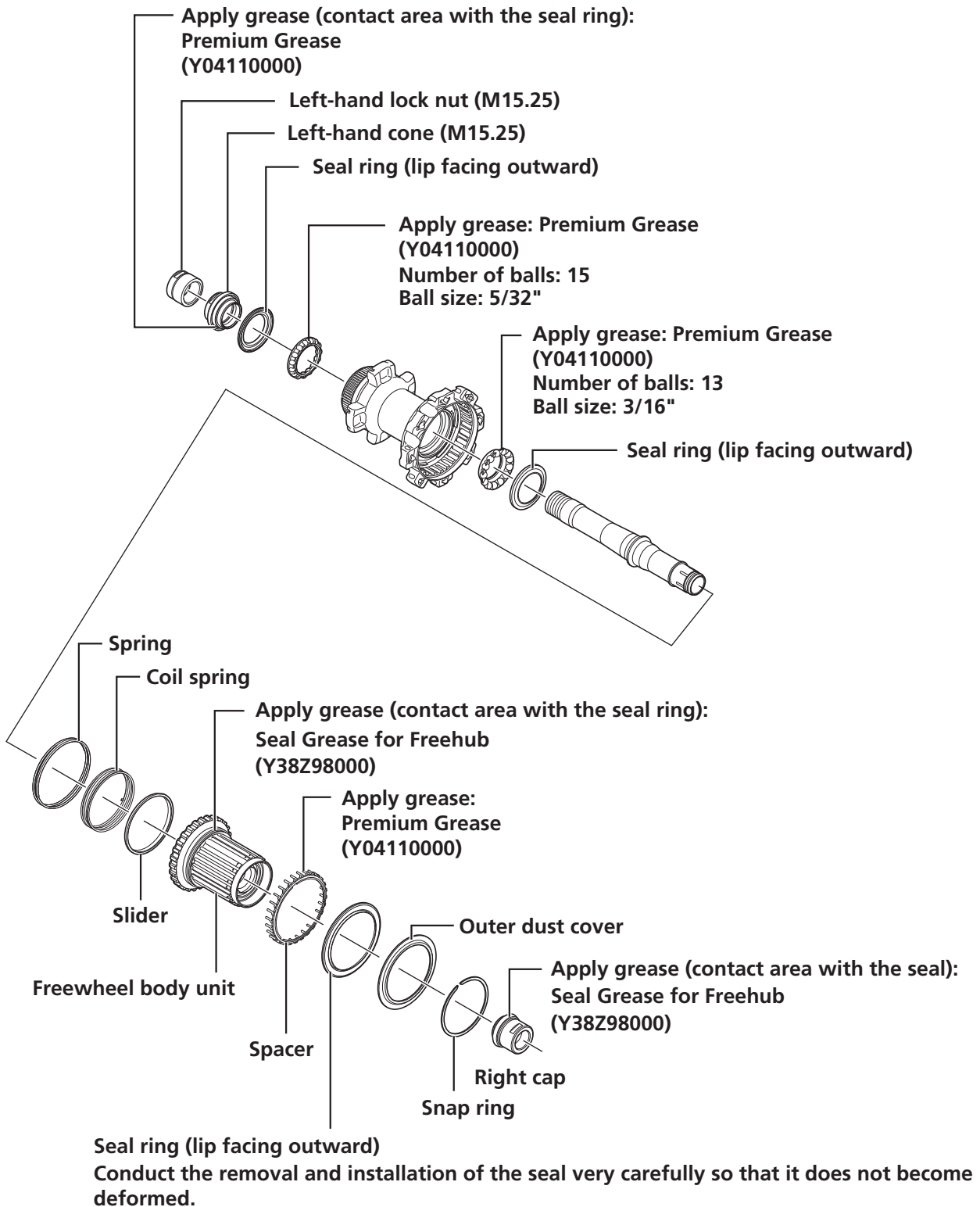

**NOTICE**

- Do not attempt to disassemble the freehub body. If this is not observed, problems with operation may occur.
- Conduct the removal and installation of the seal very carefully so that it does not become deformed. When reinstalling the seal, check that it is facing the right way and insert it as far as it will go.
- Do not attempt to disassemble the dust cover which is crimped onto the right cap and cone.
- Place the freehub body down on a work surface with the hub ratchet facing up. Spin the hub ratchet clockwise while pushing downwards on it, as shown in the figure. Ensure that this firmly engages the hub ratchet, and that the hub ratchet cannot be spun freely.

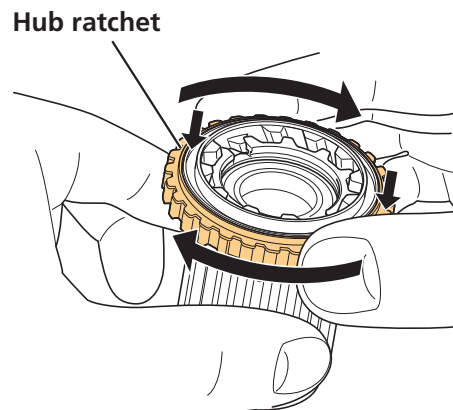

If the two hub ratchets do not engage, reset the position of the ratchets by turning clockwise while pulling up on the hub ratchet, then repeat the previous step. If the rings fail to firmly engage after several attempts, it may be indicative of a fault in the freehub body.

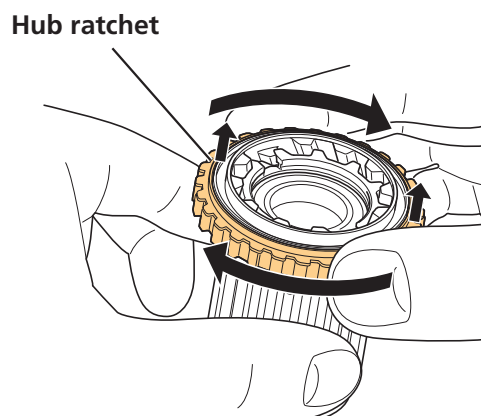

**NOTICE**

- The correct position for the dust cover is where it is hidden in the freewheel body unit, as shown in illustration (A). If the dust cover is in the position shown in illustration (B), repeat the assembly process from the beginning.

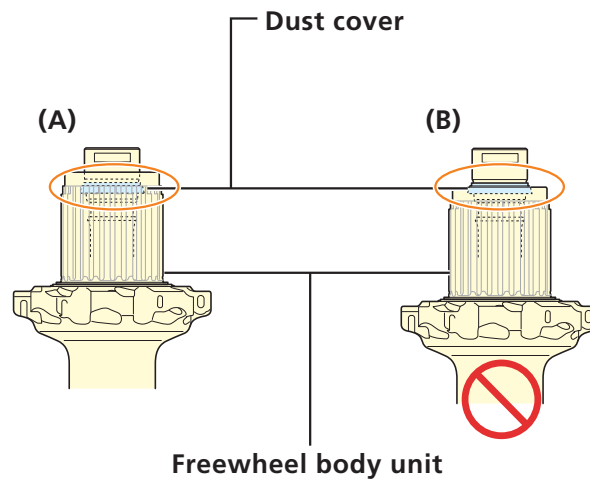
**Disassembly (WH-R8170 / WH-RS710)**

1. Loosen the lock nut on the double-lock section on the left side of the hub body.

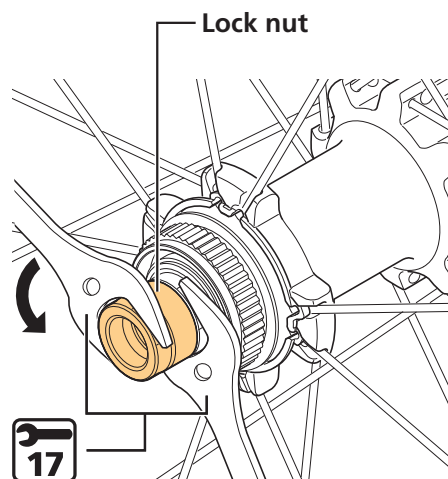

## 2. Remove the lock nut, cone, and seal ring.

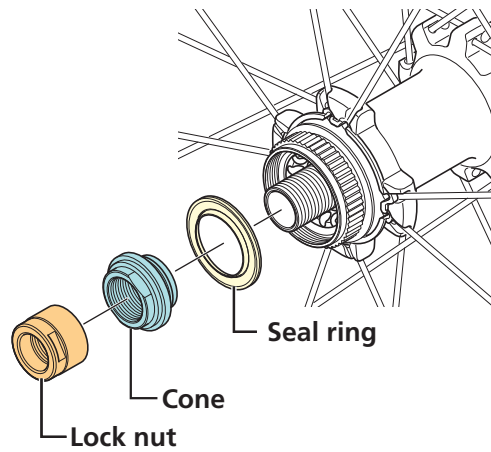

## 3. Remove the hub axle from the right side of the hub body.

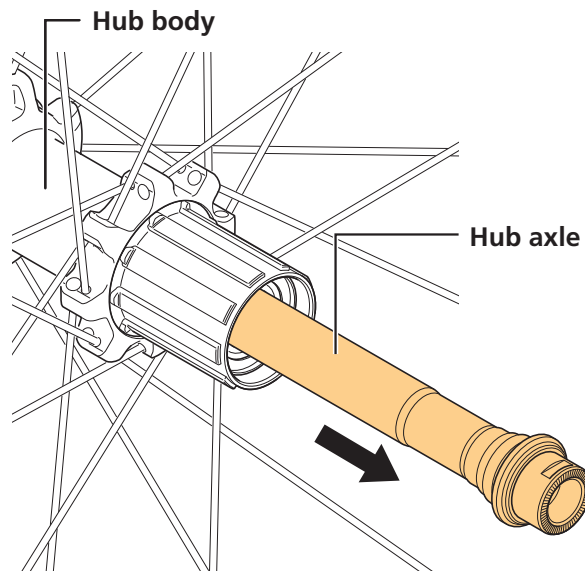

**4.** The unit can be disassembled as shown in the figure. Apply grease to the indicated parts at periodic intervals.

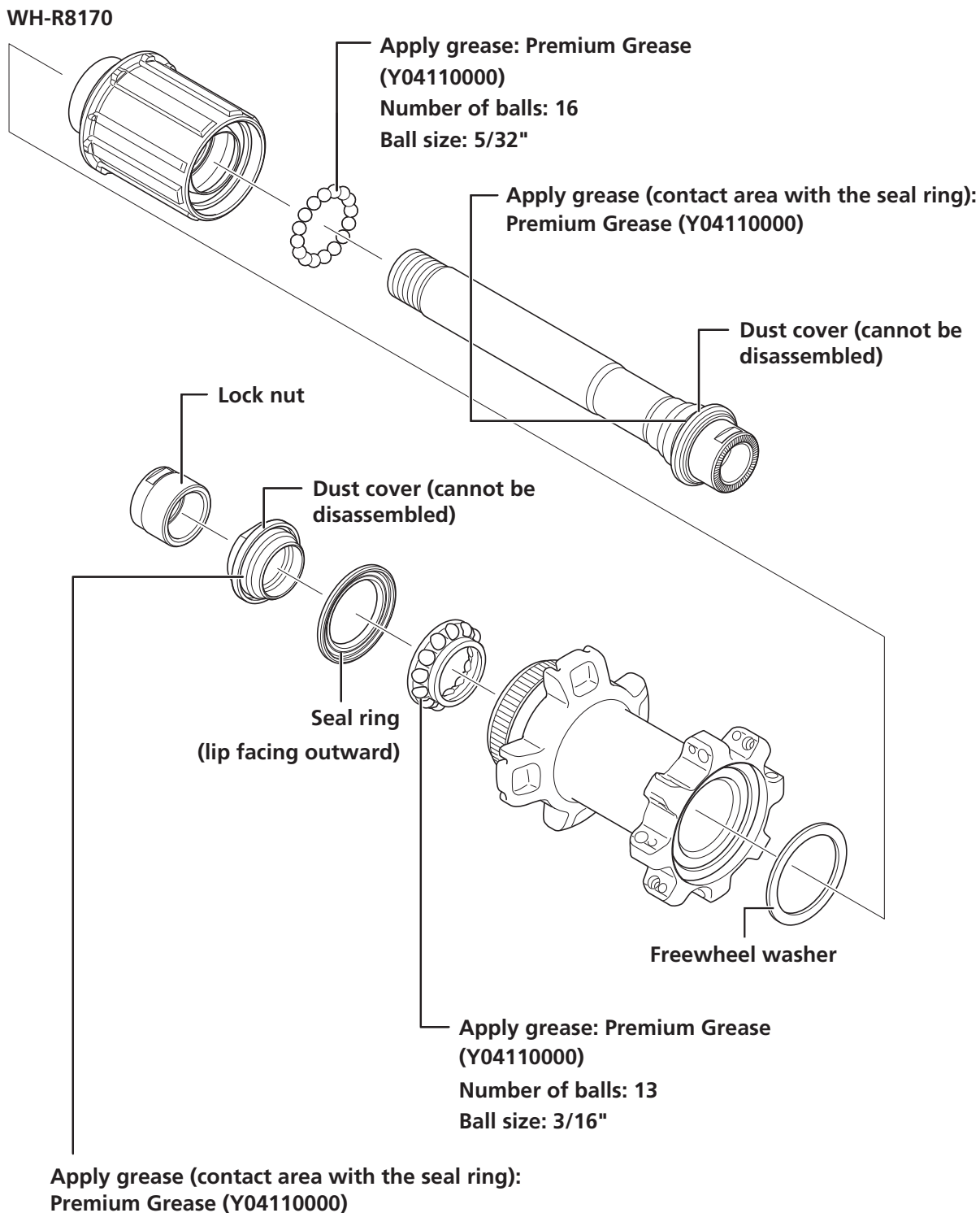

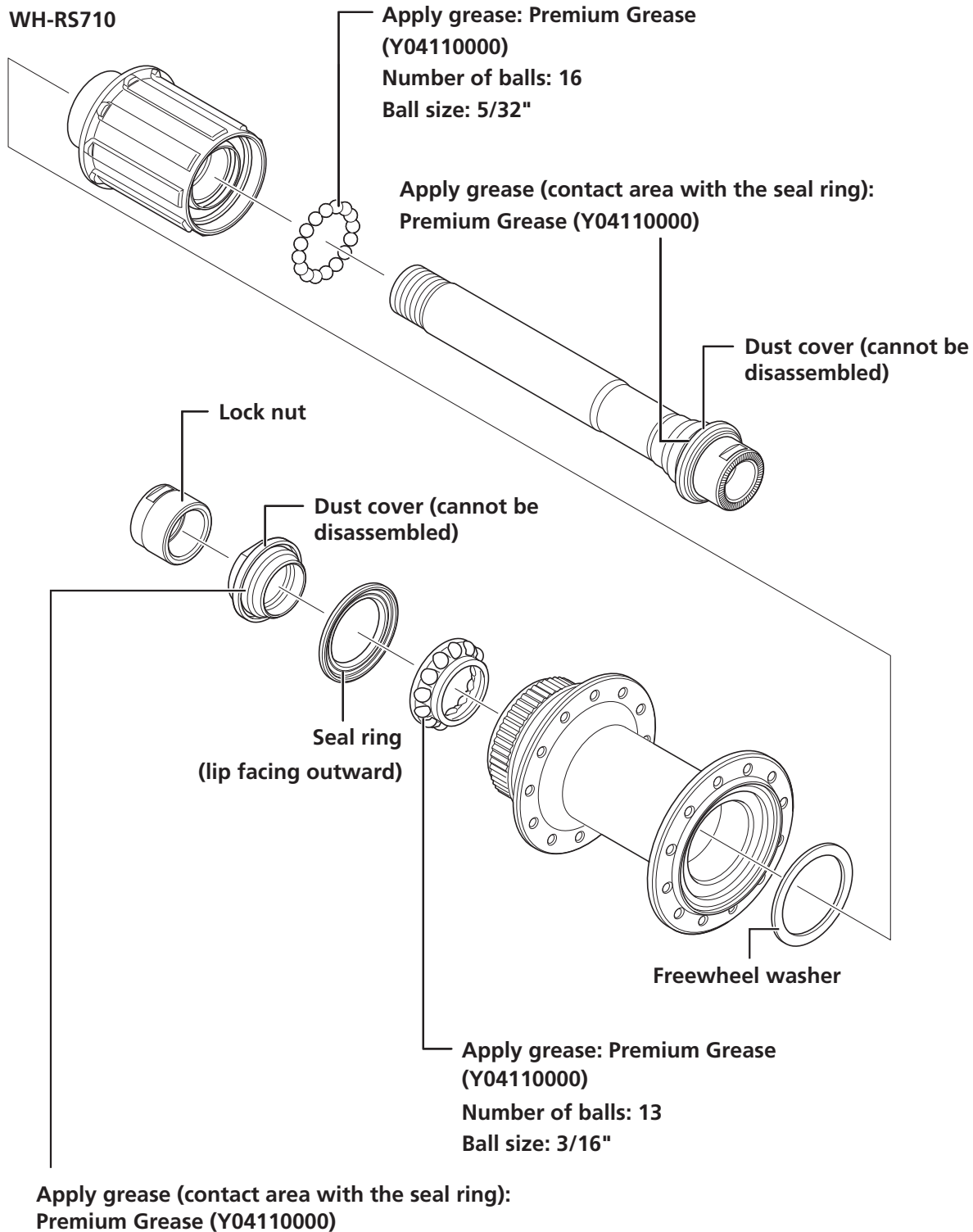

**NOTICE**

- Conduct the removal and installation of the seal very carefully so that it does not become deformed. When reinstalling the seal, check that it is facing the right way and insert it as far as it will go.
- Do not disassemble the dust covers which are crimped onto the axle, the right nut and the cone.
- Do not attempt to disassemble the freewheel body unit, because it may result in a malfunction.
- The correct position for the dust cover is where it is hidden in the freewheel body unit, as shown in illustration (A). If the dust cover is in the position shown in illustration (B), repeat the assembly process from the beginning.

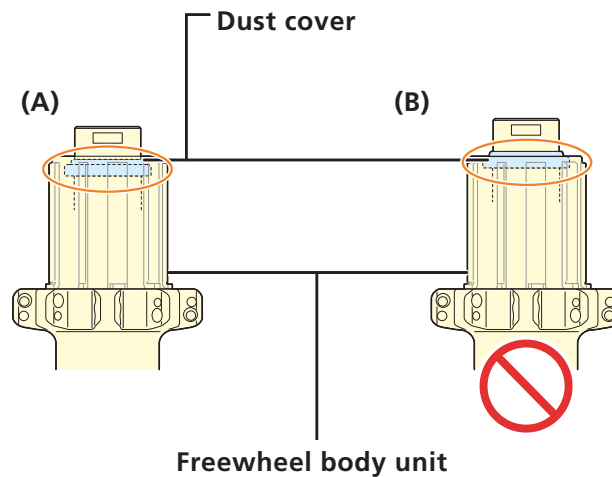

## Assembly (WH-R9270)

### ► Installing the hub axle

#### 1. Install the necessary parts such as the hub axle.

Install it in the reverse order from the disassembly.

- 2.** After installing the axle to the hub body, apply grease to the axle threads.

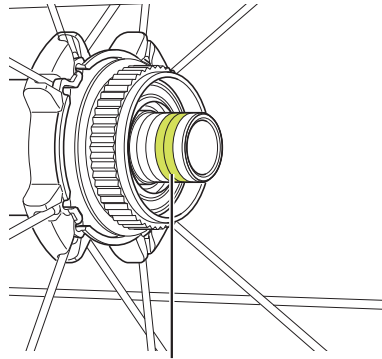

Apply grease:  
Premium Grease  
(Y04110000)

- 3.** After adjusting the bearing preload, tighten the lock nut on the left side of the hub body and double-lock the assembly.

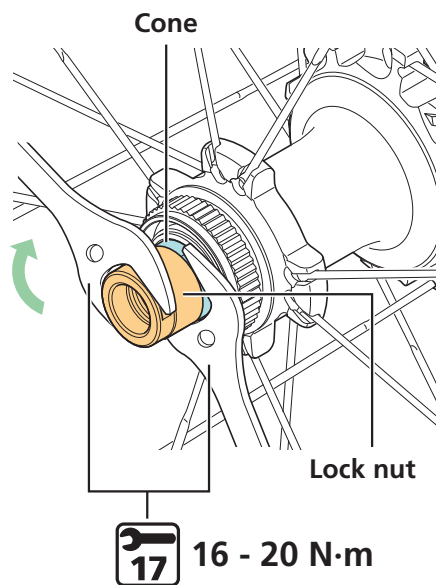

### NOTICE

- Apply Premium Grease to the contact area with the seal ring. Do not mix in any other type of grease. Only apply a thin film of grease by hand to each area.

Apply grease (contact area with the seal ring):  
Premium Grease  
(Y04110000)

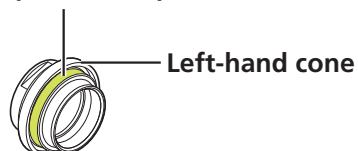

## ▶ Installing the spring / coil spring

### 1. Fit the spring into the groove in the hub.

Insert the spring into the groove specified in the figure.

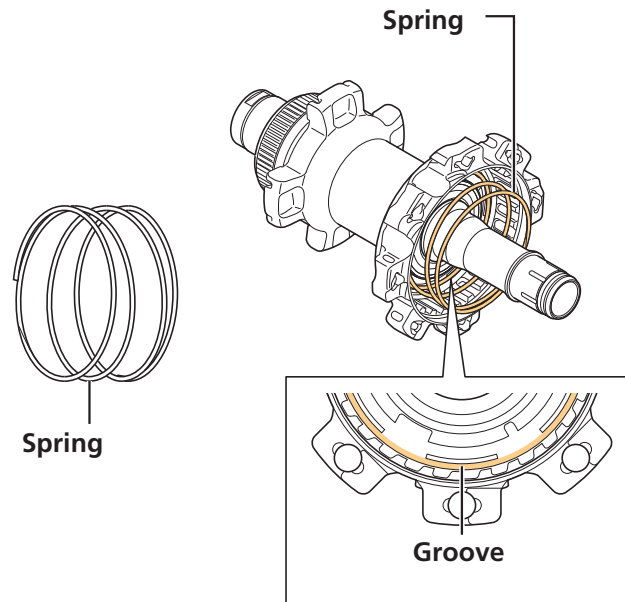

#### **NOTICE**

- The coil spring and spring have different shapes.

Coil spring

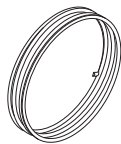

Spring

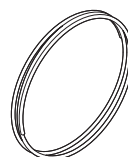

## 2. Fit the coil spring into one of the grooves in the hub.

Fit the stopper hook into a hook engagement. There are three hook engagements in total, and any of them can be used for the installation.

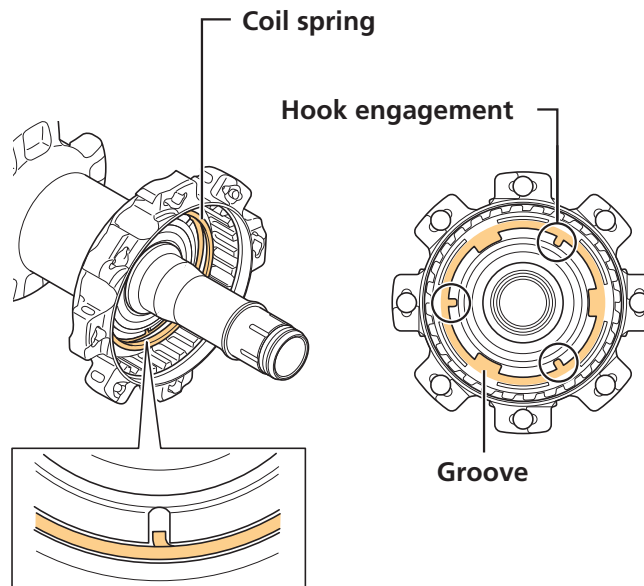

## ► Installing the slider

### 1. Set the slider on top of the coil spring.

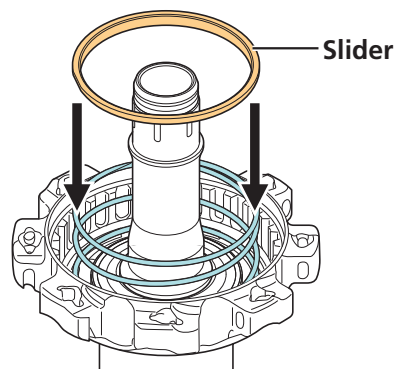

#### **NOTICE**

- Note the direction (up and down) of the slider.

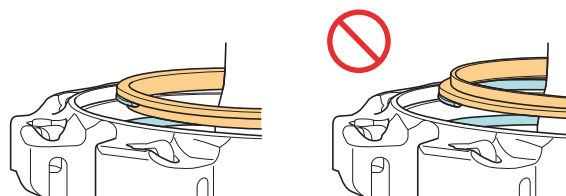

## ▶ Installing the spacer

1. Apply grease to all the spacer tips (approximately 2 mm).

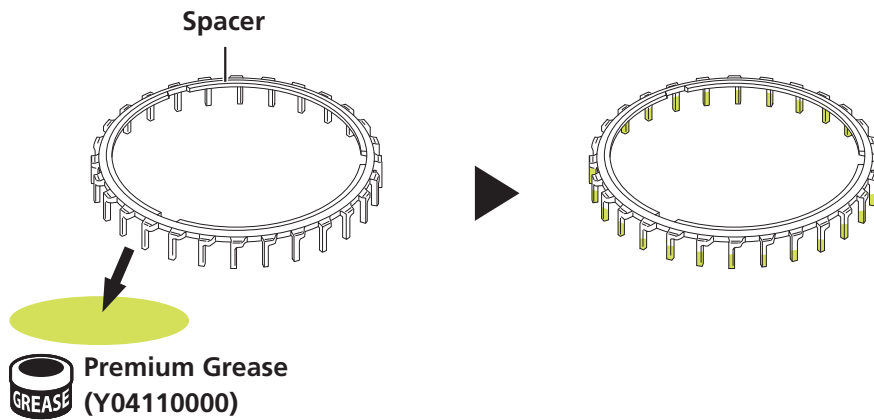

2. Install the spacer as shown in the figure.

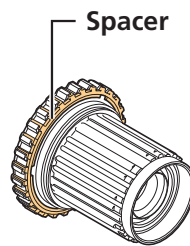

### **NOTICE**

- Pay attention to the position of the spacer.

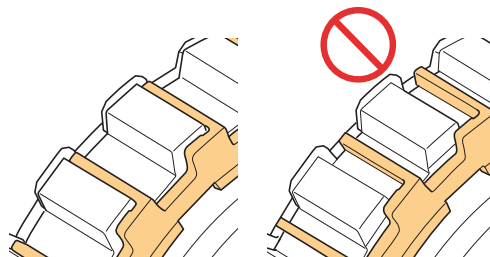

## ▶ Installing the snap ring

### 1. Apply grease to the seal portion of the right cap.

Do not apply grease outside of the indicated areas.

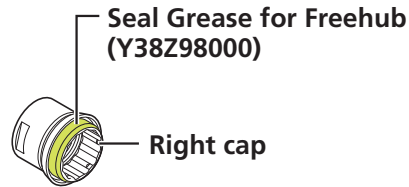

### 2. Install the freewheel body unit with spacer and right cap.

Use a clean rag to wipe off excess grease applied to the spacer.

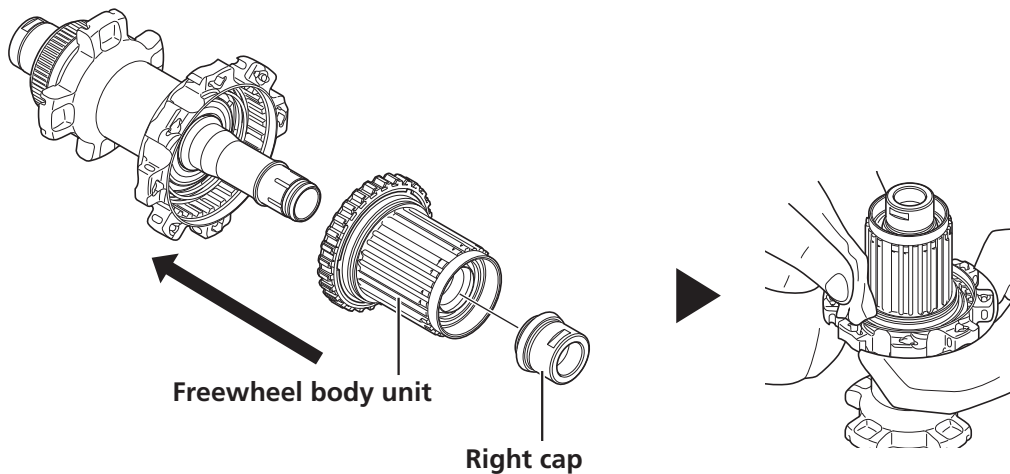

#### **NOTICE**

- When attaching the right cap to the hub axle, align the grooves of the hub axle with the protrusions of the right cap.

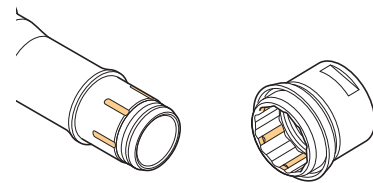

### 3. Install the seal ring.

- (1) Apply grease to the seal ring and the seal portion of the freewheel body unit. Do not apply grease outside of the indicated areas.
- (2) Ensure the lip on the inner diameter of the seal ring is facing outwards. Be careful not to damage the seal ring during installation.

(3) Use TL-FH17 to install the seal ring.

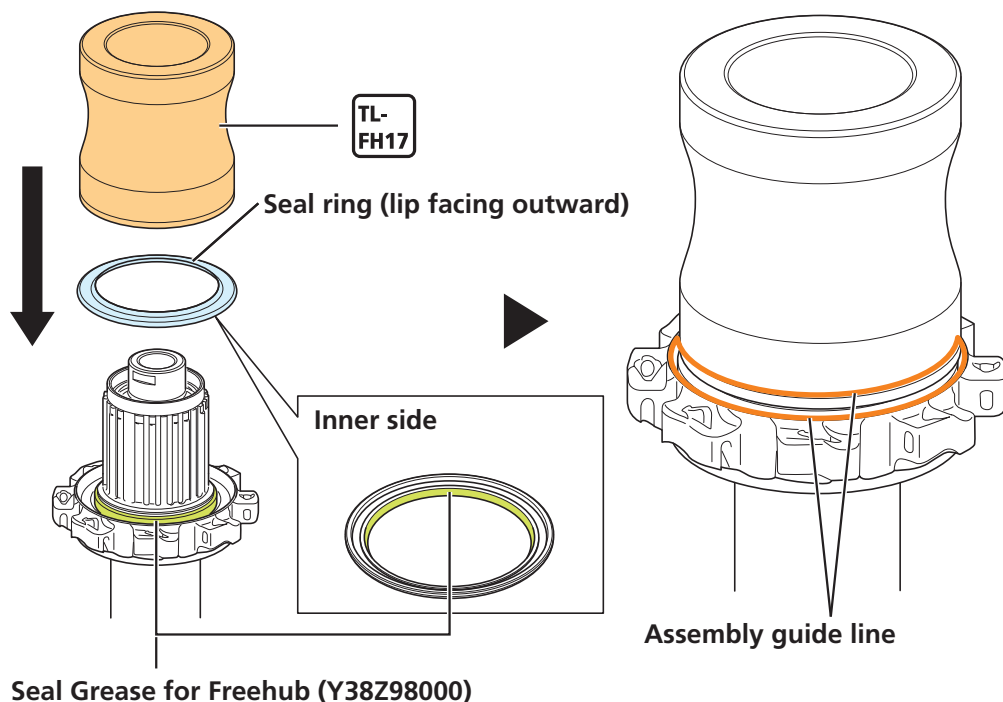

#### 4. Install the outer dust cover and snap ring.

Seat one end of the snap ring into the groove, then work it in around the circumference of the freewheel body until it is fully seated.

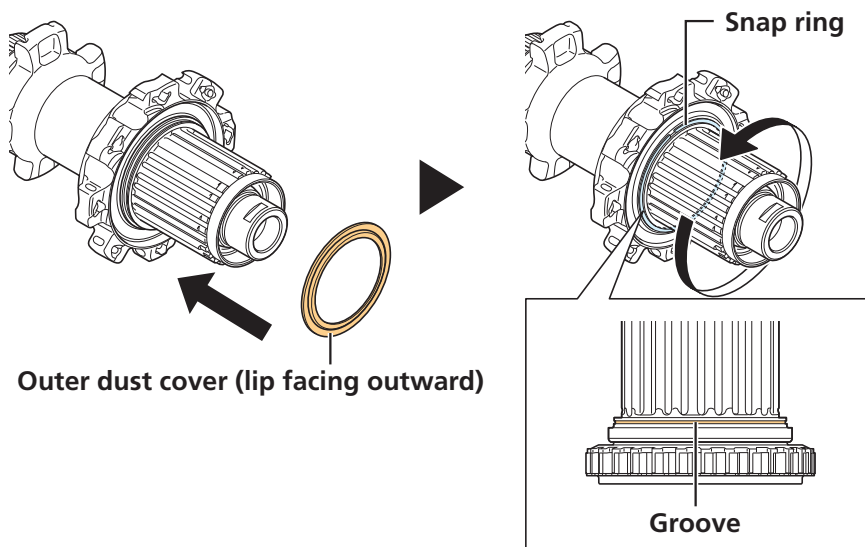

**NOTICE**

- Note the direction of the outer dust cover.

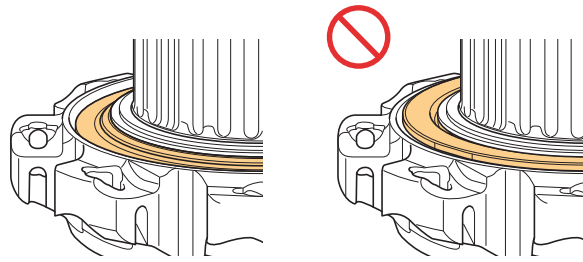

5. Double check that the snap ring is fully secured along the entire circumference of the groove.

**Assembly (WH-R8170 / WH-RS710)**

1. Install the necessary parts such as the hub axle.

Install it in the reverse order from the disassembly.

2. After installing the axle to the hub body, apply grease to the axle threads.

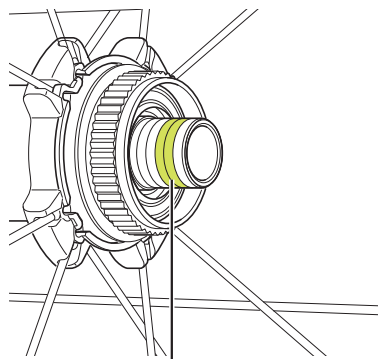

Apply grease:  
Premium Grease  
(Y04110000)

- 3.** After adjusting the bearing preload, tighten the lock nut and double-lock the assembly.

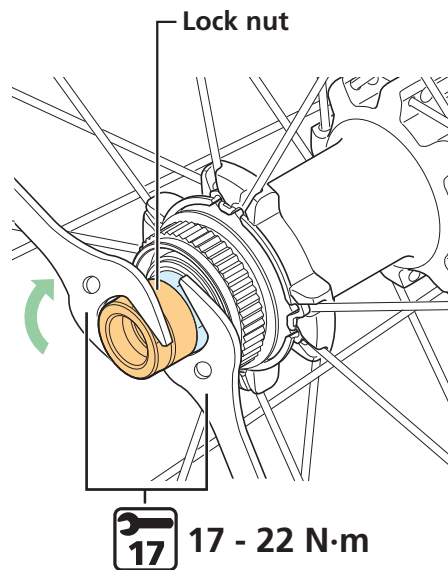

#### NOTICE

- Apply Premium Grease to the contact area with the seal ring as well as to the ball. Do not mix in any other type of grease. Only apply a thin film of grease by hand to each area.

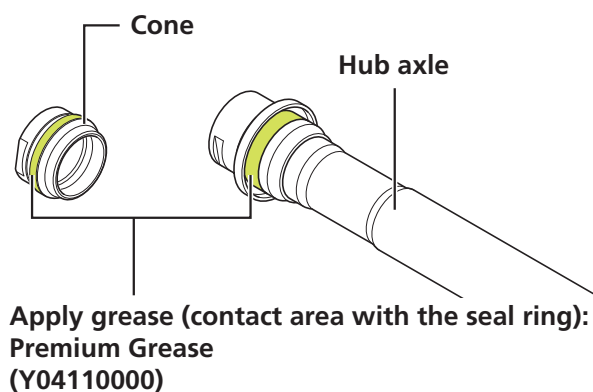

## Replacing the freewheel body unit

### WH-R9270

Refer to "Disassembly (WH-R9270)" and "Assembly (WH-R9270)" when replacing the freewheel body unit.

The procedure from step 4 in "Disassembly (WH-R9270)" is unnecessary, since the hub axle does not need to be removed.

## WH-R8170 / WH-RS710

For information on how to pull out the hub axle, refer to the "Disassembly (WH-R8170 / WH-RS710)" section in "Freehub."

1. Use the TL-FH15 to rotate the freewheel body unit in the direction shown in the figure, then remove it.

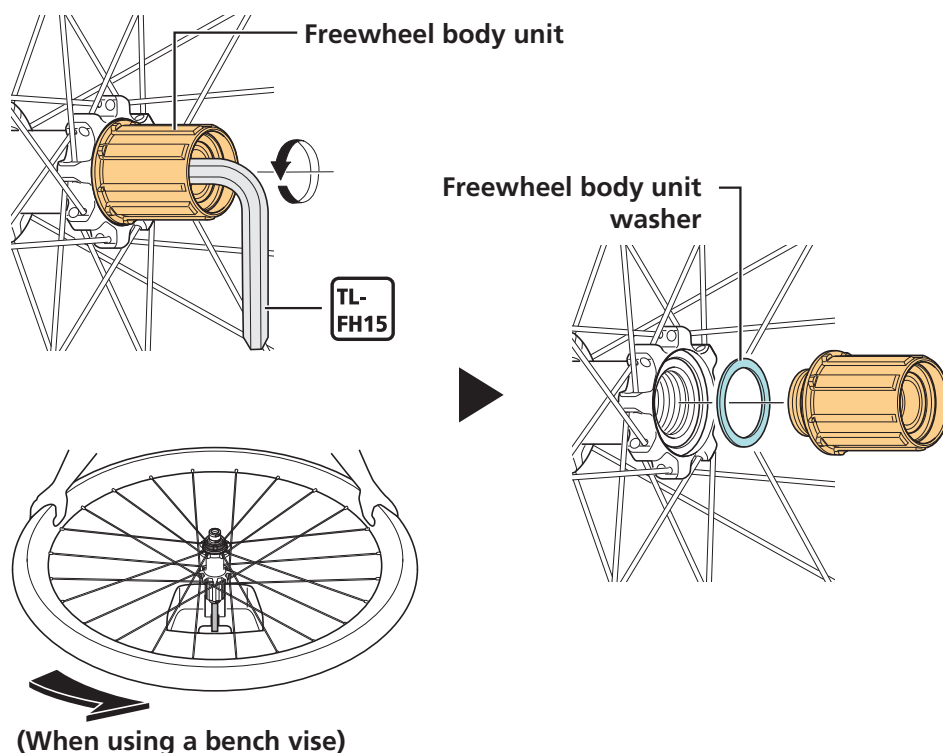

2. Install the new freewheel body unit.

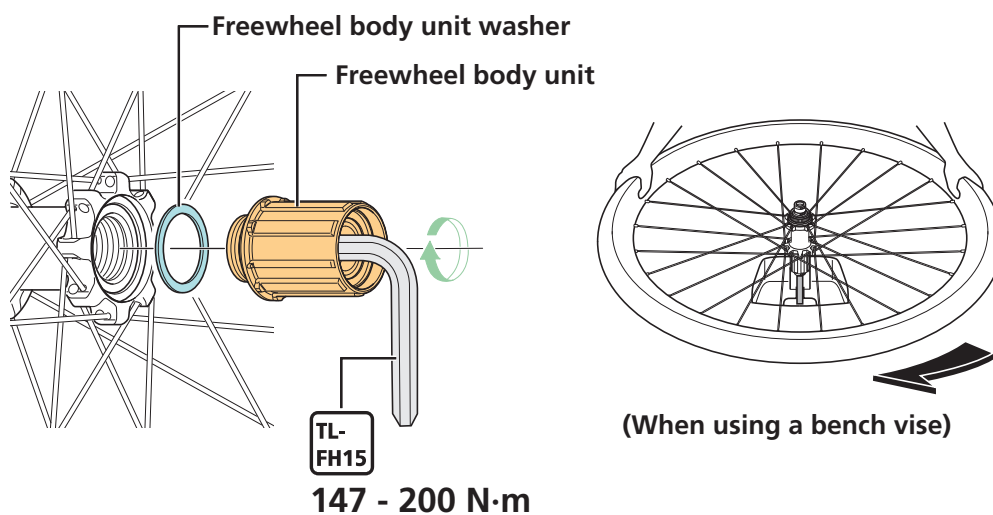

**NOTICE**

- The correct position for the dust cover is where it is hidden in the freewheel body unit, as shown in illustration (A). If the dust cover is in the position shown in illustration (B), repeat the assembly process from the beginning.

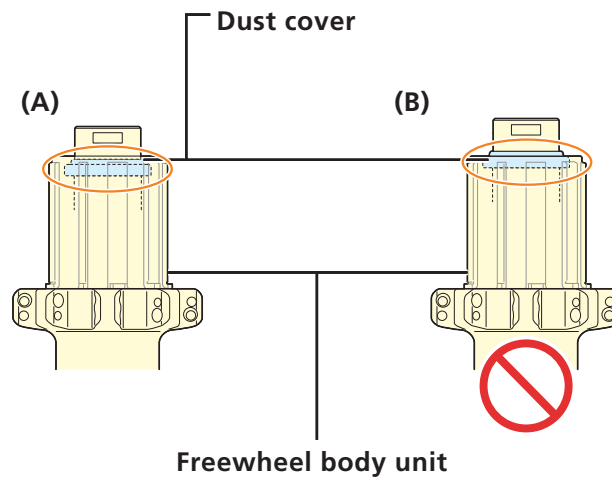

## Installing and removing the tubeless tires

### Important safety information

#### ⚠ WARNING

- The tires should be installed and removed by hand. If this is difficult, a resin tire lever for tubeless wheels may be used. In such cases, be sure to check that the rim surface has not been dented, scratched, or cracked as there is a risk of causing damage to the air seal between the tire and the rim, which would result in air leakage. For carbon rims, check that there is no carbon peeling or cracking, etc. Finally, make sure that there is no air leakage.

#### ⚠ CAUTION

- When using an inner tube, do not add additional rim tape on top of the tubeless tape. Doing so may make it difficult to install or remove the tire, and it may cause damage to the inner tube resulting in a sudden puncture, which can cause the bicycle to fall over.
- Do not overtighten the valve lock ring. If you tighten the valve lock ring too much, the valve seal may become deformed, and air leaks may occur.

**NOTICE**

- If the tires are difficult to fit, use tap water or soapy water to help them slide more easily.
- Products are not guaranteed against natural wear and deterioration from normal use and aging.

## Installation

### 1. Install the valve on the rim.

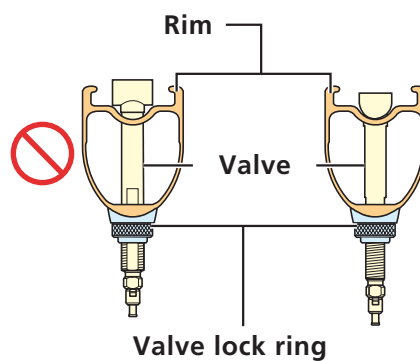
**NOTICE**

- Note the direction of the valve.
- When tightening the valve lock ring, check that the valve does not turn together with the valve lock ring.

### 2. On one side of the tire, push the bead into the center groove of the rim.

\* Check that there are no foreign particles or damage in the tire bead, rim, and valve.

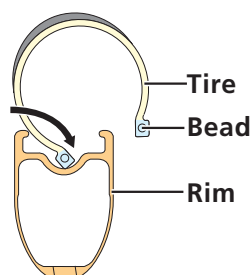

- 3.** Set the bead on the other side of the tire starting from the point opposite the air valve.

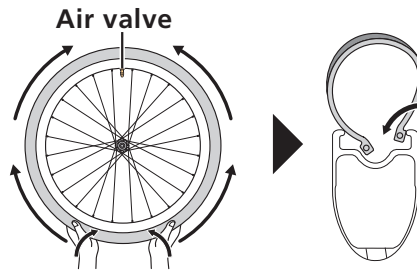
**TECH TIPS**

- If the final section of the bead at the air valve is difficult to mount, make sure the whole bead is pushed into the center groove of the rim. Start from the opposite side of the air valve and work your way around each side to the location of the air valve.

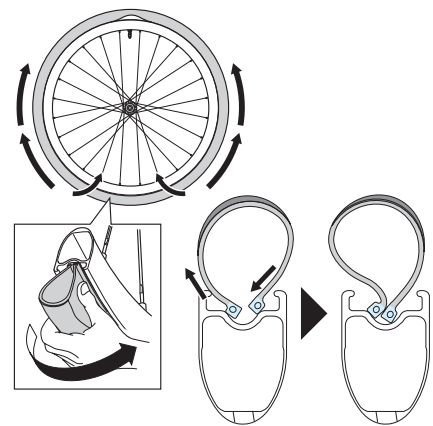

- 4.** Grip the tire with both hands and insert the tire into the rim.

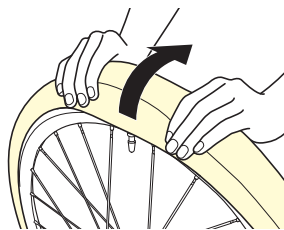

- 5.** Inflate with air to lock the beads of the tires into the rim.

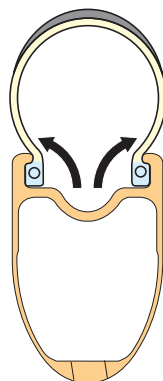

## 6. Deflate the tire and check that the beads are locked into the rim.

When deflating the tire, the tire may separate from the rim if the bead lock is released from the rim and cause air leaks while riding.

## 7. Inflate the tire until it is at an appropriate pressure.

### ⚠ WARNING

- Use the appropriate air pressure indicated on the tire and rim. If the maximum pressures indicated on the tires and rims differ, be sure not to exceed the maximum pressure with the lower value. A higher pressure than indicated can cause a sudden puncture and/or sudden release of the tire, which can result in serious injury.

WH-R9270 / WH-R8170 / WH-RS710: Maximum pressure = 7.5 bar / 109 psi / 750 kPa

## Removal

### 1. To remove the tire, deflate it and push one side of the bead into the center groove of the rim.

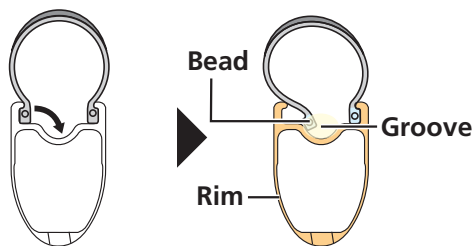

### TECH TIPS

- Be sure to only push in the bead on one side of the tire. If you push the beads in on both sides, the tires will be difficult to remove. If you accidentally unseat both beads, inflate the tire once more to lock the beads, then restart the procedure from the beginning.

## 2. Remove the beads.

Remove the bead on one side of the tire starting from the point closest to the air valve, then remove the bead on the other side of the tire.

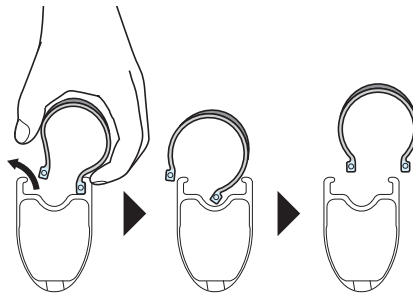

## Installing an inner tube

1. Loosen the valve lock ring and remove the air valve.

2. On one side of the tire, push the bead into the center groove of the rim.

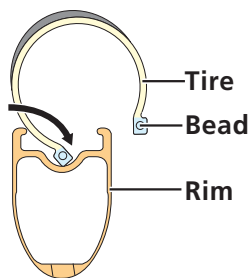

3. Insert the inner tube into the tire.

Inflate the inner tube slightly to give it a firm shape, then insert it into the tire.

### **NOTICE**

- Check that the air valve and size of the inner tube are appropriate for the rim and tire being used.

4. Insert the bead from the opposite side of the air valve.

Be careful not to pinch the tube at this time.

If necessary, use soapy water.

5. Inflate the inner tube until the tire locks into place.

# Cautions regarding the use of tubular tires and rims

## Important safety information

Compared to clincher tires, tubular tires require greater expertise when handling and mounting them. Additionally, greater care is required in their maintenance. Always inspect the wheels prior to use.

These precautions must be observed in order for the optimum performance features of this product to be obtained. If they are not observed, the tires may come off the rims or damage to the tires may occur resulting in severe injury to the rider.

Make sure that you read and fully understand the following points on using tubular tires. Furthermore, if you are not confident that you have enough knowledge and experience in installing and removing the tires or carrying out maintenance, ask an authorized bicycle dealer or a professional bicycle technician for assistance.

### **⚠ WARNING**

**Do not use these tubular tires if you are not confident that they have been installed by someone with an adequate level of knowledge and experience.**

- When securing the tires to the wheel rims, use a special adhesive designed exclusively for tubular tires. If any other type of adhesive is used, it might not secure the tires in place with sufficient force, and it may also cause deterioration of the rim material.
- When cleaning the rim surfaces, use only a cleaning agent which is exclusively designed for tubular tires. If any other type of cleaning agent is used, it may cause deterioration of the rim material. If using carbon rims, do not rub the surfaces of the rims vigorously with sandpaper or anything similar. Otherwise, the carbon fiber layer of the rims may peel off when replacing the tires.
- Confirm that the tire is secured to the rim surface before using it. If the adhesive is not applied correctly to the rim surfaces, it may not hold the tires securely in place, and the tires may easily come off the rims. Particularly when using the rims for the first time, always be sure to clean the rim surfaces thoroughly with the correct cleaning agent to remove any traces of grease and other foreign materials, then apply a thin layer of adhesive to the rim surface to create a secure bond between the rim and the wheel. When this has been done, apply more adhesive evenly to the rim at a thickness which is just sufficient to cover the roughness of the tire and no more, then install the tire. When using rims that contain carbon fiber material, if the tires are not attached properly, or if the wrong type of adhesive or cleaning agent is used, it may not be possible to obtain the same adhesion force between the rim and the tire as with aluminum rims, and the strength of the carbon fiber rims may also be reduced.

**⚠ WARNING**

- Understand the properties of the adhesive before using it. Depending on the type of adhesive used, there may be large differences in factors such as adhesion force, the time it takes to dry, durability, and the sensitivity to conditions such as temperature and humidity. Therefore, you should pay particular attention to the adhesion force when using the wheels.
- Always check the tires before use by applying force to the tires to make sure they are properly attached to the rims.
- The adhesion force of the tires may deteriorate after long periods of use, therefore it is best to re-apply the adhesive periodically. If using carbon rims, use a rim cement cleaner or similar when replacing the tires to assist in peeling the tires off gently in order to avoid pulling away the carbon fiber layer.
- Take care of the adhesive force of the tire and rim surface. If you do not apply any adhesive to the adhesion surface of the tire when installing the tire to the rim, the adhesion force between the tire and the rim will be weaker. If you want the tires to adhere to the rims with greater force (such as when riding in criterium competition races and track races where hard turning and acceleration are required) you can use adhesive to adhere them more firmly.
- Take care when continuously using the brake. If the rims become hot as a result of continuous use of the brakes when riding down long descents, sudden loss of tire adhesion force may occur. If you think that this might happen at some stage, pay particular attention to selecting and re-applying the adhesive at some point. Loss of adhesion force can still occur even if measures are taken to prevent it, so if it still occurs, replace the wheels and discontinue using the tubular type of tires.
- Also check the tires before use. If there are large cracks in the tires, they may burst during use, and so they should be replaced beforehand. In addition, the seam covers may come off the tires after long periods of use, and so check the tires before riding the bicycle.
- If you feel a problem or abnormality, stop using the bicycle and consult a place of purchase or a distributor.
- For any questions regarding methods of installation and maintenance, please contact your place of purchase or a distributor.

**NOTICE**

- If any adhesive gets on the painting surface of the rim, use a cloth to wipe it off before it dries. Do not use cleaning solvents or chemicals, such as rim cement cleaners, as they may remove the paint.

# SHIMANO

**SHIMANO NORTH AMERICA BICYCLE, INC.**

One Holland, Irvine, California 92618, U.S.A. Phone: +1-949-951-5003

**SHIMANO EUROPE B.V.**

High Tech Campus 92, 5656 AG Eindhoven, The Netherlands Phone: +31-402-612222

**SHIMANO INC.**

3-77 Oimatsu-cho, Sakai-ku, Sakai City, Osaka 590-8577, Japan

Please note: specifications are subject to change for improvement without notice. (English)

© Dec. 2021 by SHIMANO INC. ITP